

## WSO Mist Collector

WSO 25-4 and 25-6

### Installation and Operation Manual

Installation, Operation, and Service Information

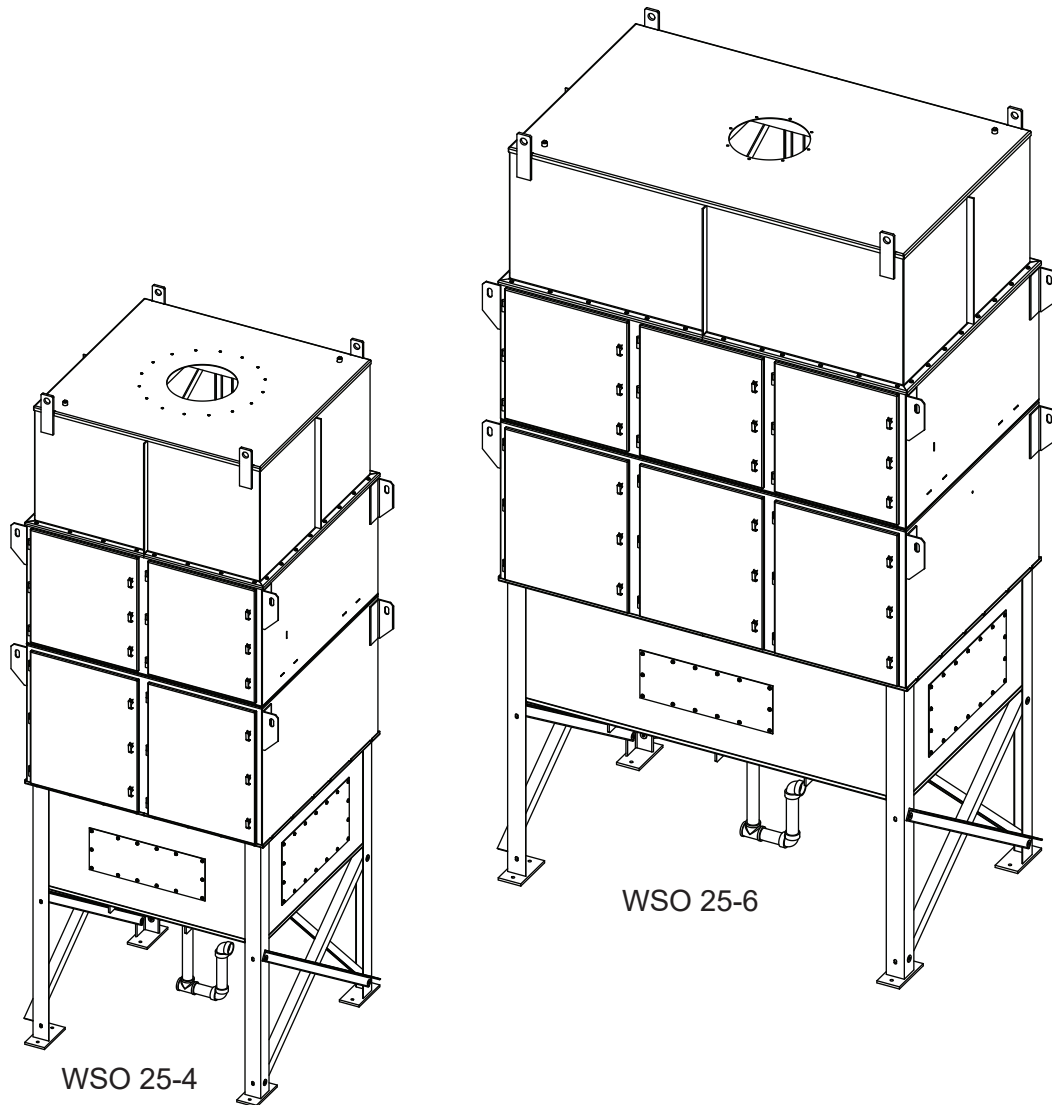

This manual contains specific precautions related to worker safety. The hazard alert image denotes safety related instructions and warnings in this manual. DO NOT install, operate, or perform maintenance on this collector until you have read and understood the instructions, precautions and warnings contained within this manual.

## IMPORTANT NOTES

This manual has been supplied to assist with the installation, operation and maintenance for the collector purchased. Please read the manual before installing, operating, or performing maintenance on the collector as it contains specific precautions for worker safety. It is the owner's responsibility to ensure that this manual is available for use by installers, operators and maintenance personnel that will be working with this collector. This manual is the property of the owner and should be left with the collector when installation has been completed. **DO NOT** operate this collector until you have read and understood the instructions and warnings located in the installation and operation manual.

For additional copies of this manual, contact Donaldson Torit.



The Safety Alert Symbol indicates a hazardous situation which, if not avoided could result in death or serious injury. Obey all safety messages following this symbol to avoid possible injury or death. The possible hazards are explained in the associated text messages.

### **NOTICE**

NOTICE indicates a potential situation or practice which is not expected to result in personal injury, but which if not avoided, may result in damage to equipment.

## Contents

IMPORTANT NOTES .....	i
1 Safety Communication .....	1
2 Product Description .....	3
Standard Equipment .....	4
First Stage Filter .....	4
Primary Filter .....	4
Final Filter (Optional) .....	4
P-Trap with Optional Y-Strainer .....	4
Sprinkler Coupling .....	4
Options and Accessories .....	4
Final Filter .....	4
Drain Collection Container .....	4
Cleaning Controls and Sensors .....	4
3 Operation .....	5
4 Product Service .....	6
Operational Checklist .....	6
Filter Replacement .....	7
P-Trap Service .....	9
P-Trap with Y-Strainer, Screen Cleaning and Removal .....	9
Options and Accessories .....	10
Fan Controls .....	10
Drain Collection Container .....	10
Troubleshooting .....	11
Appendix A - Installation .....	13
Installation .....	14
Location and Site Selection .....	14
Delivery and Inspection .....	14
Unloading and Positioning .....	14
Support Installation .....	15
Electrical Wiring .....	15
P-Trap Installation .....	17
Inlet Plenum Installation .....	17
Options and Accessories .....	18
Cleaning Controls and Sensors .....	18
Magnehelic Installation .....	18
Damper and Silencer, TBI (WSO Unpowered 25-4 and 25-6) .....	20
Top Mount .....	20
Support Brackets, Top Mount .....	20
Sprinkler Coupling .....	21
Pre-Wired Collectors .....	22
Unwired Collectors .....	22
Start-up / Commissioning .....	23
Decommissioning Collector .....	24
Product Information .....	25
Service Notes .....	26
Donaldson Industrial Air Filtration Warranty .....	28

## 1 Safety Communication



Improper operation of mist collectors and/or mist control systems may contribute to conditions in a work area or facility which could result in severe personal injury, and product or property damage. All mist collection equipment should be used only for its intended purpose and should be properly selected and sized for its intended use.

Process owners have important responsibilities relating to identifying and addressing potential hazards in their processes. When the potential for handling combustible mist exists within a process the process owner should include combustion hazards in their risk management activities and should comply with applicable codes and standards related to combustible mist.

Electrical installation must be performed by a qualified electrician.

This equipment is not designed to support site ducts, piping, or electrical services. All ducts, piping, or electrical services must be adequately supported to prevent injury and/or property damage.

Site selection must account for wind, seismic zone, and other load conditions.

Equipment may reach peak sound pressure levels above 80 dB (A). Noise levels should be considered when selecting collector location.

Most mists present safety and health hazards that require precautions. Wear eye, respiratory, head and other protection equipment suitable for the type of mist.

Some components may be heavier than they appear. Use appropriate lifting methods to avoid personal injury and/or property damage.

## Combustible Mist Hazards

Among other considerations, the current NFPA standards require owners whose processes involve potentially combustible materials to have a current Dust Hazard Analysis, which can serve as the foundation for their process hazard mitigation strategy. Mitigation may include but is not limited to:

- Prevention of all ignition sources from entering any dust collection equipment.
- Selection and implementation of fire and explosion mitigation, suppression, and isolation strategies appropriate for the risks in their process.
- Development and use of work practices to maintain safe operating conditions, and to ensure combustible dust does not accumulate within their plant or process equipment.

Donaldson designs, manufactures, and sells industrial air filtration products for a wide variety of applications. Some applications may include processes or materials with inherent fire and explosion hazards. Donaldson is neither an expert nor a certified consultant in fire, spark, or explosion detection, suppression, or control. Donaldson does not provide engineering consulting services related to process or dust hazard analyses, or code and standard compliance. Complying with applicable codes and standards and managing the risks associated with the process or materials remains the responsibility of the process owner/operator. Donaldson may provide referrals to consultants, suppliers of equipment or services related to the detection and/or mitigation of sparks, fires and/or explosions, but Donaldson does not assume responsibility for any such referrals, nor does Donaldson assume any liability for the fitness of a mitigation strategy or product for a particular installation or application. The process owner's final selection of dust collectors and risk mitigation strategies should be based on the outcome of a Dust Hazard / Process Hazard Analysis performed by the process owner. Although early engagement of a dust collector supplier provides helpful insights on the availability and features of various products, process owners should consult with a combustible dust expert and/or a process safety expert before making actual product and mitigation strategy selections.

Donaldson recommends that all industrial air filtration system designs be reviewed and approved by an expert consultant who is responsible for the integrity of the system design and compliance with applicable codes and standards. It is the process owner's responsibility to understand the risks in their process and mitigate those risks in accordance with all applicable laws, regulations and standards, including those published by the NFPA. Donaldson also recommends that proper maintenance and housekeeping procedures and work practices be evaluated, developed, and followed to maintain any industrial air filtration products in safe operating condition.

Many factors beyond the control of Donaldson can affect the use and performance of Donaldson products in a particular application, including the conditions under which the product is used. Since these factors are uniquely within the user's knowledge and control, it is essential the user evaluate the Donaldson products to determine whether the product is fit for the particular purpose and suitable for the user's application. All products, product specifications, and data (airflow, capacity, dimensions, or availability) are subject to change without notice, and may vary by region or country.

## 2 Product Description

Designed for versatility, the WSO (Water, Smoke, and Oil) mist collector is specifically engineered for water-based, smoke, and oil-based mist applications. WSO Mist Collector, Models WSO 25-4 and 25-6 collect airborne mist such as oil, water-soluble, semi-synthetic and synthetic coolant from machining operations. Two stages of filtration, plus an optional HEPA or 95% DOP filter, provide a cleaner, healthier work environment as well as a more cost effective means of mist collection. With nominal airflow capacities of 7,400 cfm for WSO 25-4 and 11,100 cfm for the WSO 25-6, the WSO is a strategic component to meeting industrial and government air-quality standards. The high efficiency filter cartridges allow air and coolants to be recycled.

Designed to increase the versatility of the collector, a variety of filter media specifically designed for mist collection is a standard offering on the product line. The WSO 25-4 and 25-6 contain a 25 inch tall primary filter uniquely designed for either water-based coolants, straight oils, or thermally-generated smoky applications. Standard options include drain collection containers, P-Traps, and afterfilters.

WSO models 25-4 and 25-6 are available with or without a fan blower and motor.

### Intended Use

Airborne mist is small droplets of metalworking fluids suspended in the air. Metalworking fluids include straight oils, water-soluble coolants, semi-synthetic and synthetic coolants. These fluids perform a variety of functions such as lubricating or cooling the part or the tool, flushing chips away from the part, and suppressing dust and smoke.

Mist is created two ways: mechanical action or thermal effects. Mechanical action involves coolant used for light lubrication and generally creates mist greater than one micron in size. Thermal effects occur when heat vaporizes the coolant, the vapor cools and recondenses into a mist. Thermal effects create mist from 0.01 to 1 micron in size. Other contaminants, such as dust from the part or the tool or smoke from the vaporization of the oil or coolant are also generated when using metalworking fluids.

The WSO mist collector is not designed to handle water mist alone. There should be some type of oil content to allow coalescing or water vapor will simply pass through the filters. The extremes of very heavy oil and light, thin oil should be avoided. Very heavy oil, similar to tar consistency, will not drain while very light, thin oil, similar to paint thinner consistency, may evaporate.

### Rating and Specification Information

General rating and specification information can be found in the product literature provided with the collector and is available on the Donaldson website. For specific load values for a collector, see the Specification Control Drawing shipped with the collector.

## Standard Equipment



The collector has a high center-of-gravity and may overturn if not secured properly.

Secure the collector to the lifting device.

Use care when moving the collector.

The WSO mist collector is shipped in three sections, a hopper plenum, a primary filter plenum and a fan support plenum. If there is an afterfilter plenum, it will ship attached to the fan support plenum. The fan will ship loose.

### First Stage Filter

Air laden with dirt and coolant mist passes through the dirty air inlet and into the hopper. First it passes through a reusable first stage filter designed to collect and coalesce large coolant droplets which drain into the hopper.

### Primary Filter

After passing through first stage filter, prefiltered air then passes through a primary filter where fine coolant droplets and mist coalesce and again drain into the hopper.

### Final Filter (Optional)

Filter air can then be passed through a final filter to separate fine dust particulates which may have passed through the primary filter.

### P-Trap with Optional Y-Strainer

Dirty coolant collected in the hopper flows through a standard P-Trap designed to drain coolant while maintaining a seal. Dirt can be removed from the P-Trap by flushing with coolant or opening the optional strainer.

### Sprinkler Coupling

Sprinkler couplings are provided for the convenience of fire control system installers. The fire control system installer shall make their own decisions on the appropriate location of fire control system components.

## Options and Accessories

### Final Filter

Filter air can then be passed through a final filter to separate fine dust particulates which may have passed through the primary filter.

### Drain Collection Container

The optional drain collection container is intended for use where small amounts of liquid are collected and requires regularly scheduled maintenance. Failure to empty the collection bottle will result in inlet plenum overflow.

## Cleaning Controls and Sensors

### Magnehelic® Gauge

The Magnehelic is a differential pressure gauge used to measure the pressure difference between the clean- and dirty-air plenums and provides a visual display of filter change requirements. The high-pressure tap is located in the dirty-air plenum and the low-pressure tap is located in the clean-air plenum.

### 3 Operation

Electrical work during installation, service or maintenance must be performed by a qualified electrician and comply with all applicable national and local codes.

Turn power off and lock out all power before performing service or maintenance work.

Check that the collector is clear and free of all debris before starting.

Do not install in classified hazardous atmospheres without an enclosure rated for the application.

During normal operation, contaminated air enters the collector through one or both dirty-air inlets located on each side, toward the bottom of the collector. The incoming air slows and turns upward, causing large mist droplets and particles to fall out of the air stream and into the hopper. The air passes through a reusable first-stage filter designed to collect and coalesce large droplets and particles.

The primary stage of filtration is the pleated filter cartridge specifically designed to collect, coalesce, and drain fine mist. As the mist coalesces, the droplets are big enough to run down the cartridge and drain back into the collector. The droplets will drain on both the inside and outside of the cartridge. Liquid that collects on the inside of the cartridge drains through the bottom portion of the porous media and into the hopper. Clean, mist-free air exits the cartridge and discharges through the top of the collector.

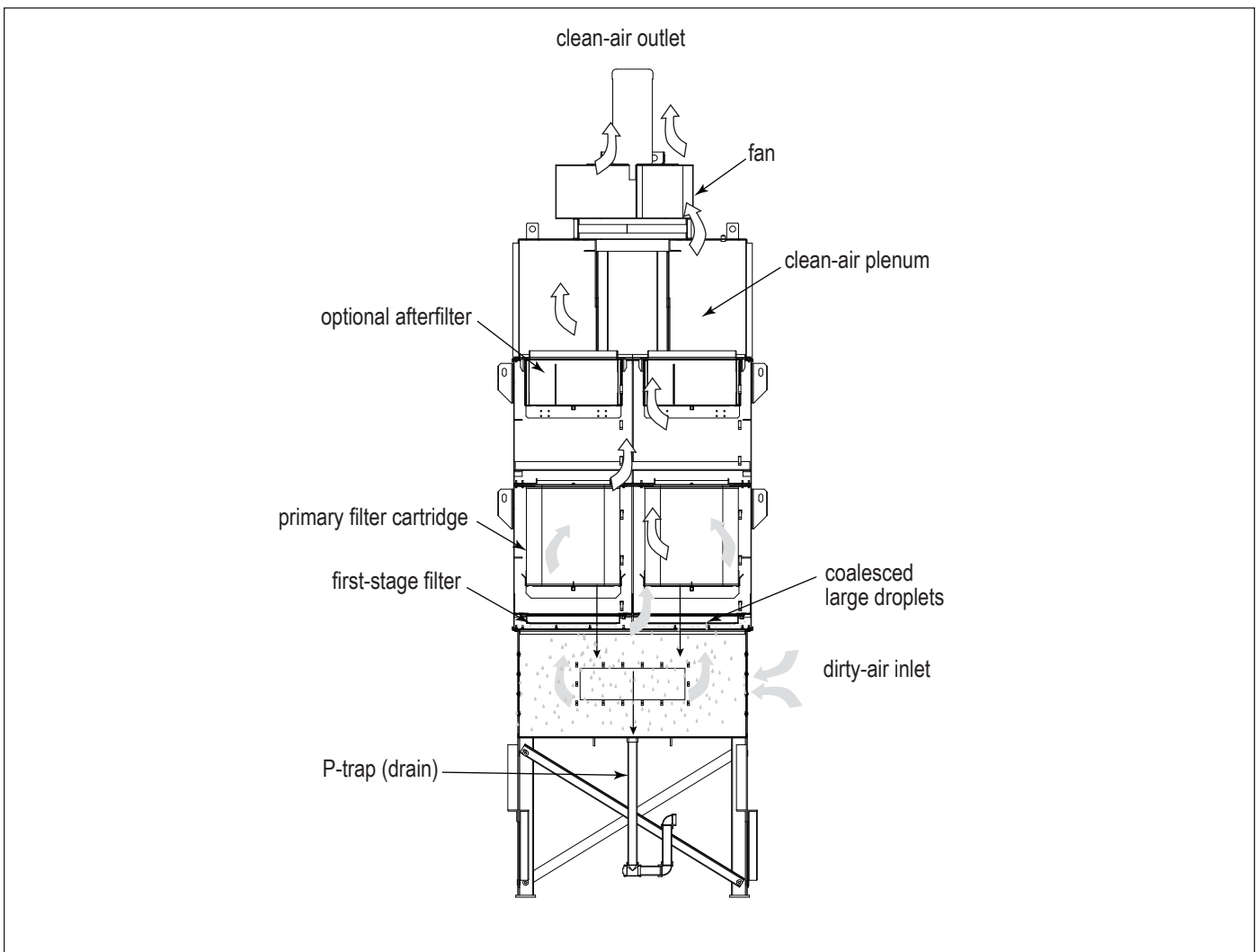

Collector Operation, WSO 25-4 shown

## 4 Product Service



During service activities there is some potential for exposure to the mist in the collector. Most mists present safety and health hazards that require precautions. Wear eye, respiratory, head and other protection equipment suitable for the type of mist when performing any service activities.

Use appropriate access equipment and procedures. Note the standard collector is not equipped with access platforms unless noted on the specification drawings.

LOCK-OUT all energy sources prior to performing any service or maintenance on the equipment.

Electrical service or maintenance work must be performed by a qualified electrician and comply with all applicable national and local codes.

### Operational Checklist

1. Monitor the physical condition of the collector and repair or replace any damaged components.  
Routine inspections will minimize downtime and maintain optimum system performance. This is particularly important on continuous-duty applications.
2. Monitor pressure drop across filters.  
Abnormal changes in pressure drop may indicate a change in operating conditions and possibly a fault to be corrected.
3. Monitor exhaust.
4. Monitor hopper drainage. If slow or stopped, check hopper for obstructions and clean as necessary.
5. Check that the P-Trap is full. Refill if low or dry.
6. If equipped with a HEPA or 95% DOP, monitor pressure drop across after filter. Initial final filter pressure drop is approximately 1-2"wg. Replace the final filter when the gauge reads 3.5 to 4.0"wg. Do not attempt to clean or wash the final filter. Replace only.

**NOTICE**

Do not operate the collector without the first- or primary-stage filter in place. Significant reduction in final filter life can result.

## Filter Replacement



Most mists present safety and health hazards that require precautions. Wear eye, respiratory, head and other protection equipment suitable for the type of mist.

Use proper safety and protective equipment when removing contaminants and filters.

Dirty filters may be heavier than they appear. Use appropriate lifting methods to avoid personal injury and/ or property damage.

Turn power OFF and lock out all power before performing service or maintenance work.

Do not operate with missing or damaged filters

### First Stage Filter

Remove the first stage filter through the lower access door. Clean the first-stage screen by tapping it gently over an appropriate waste container. If further cleaning is required, wash in an appropriate wash tank. To clean the first-stage filter, soak in an appropriate wash tank, rinse, dry, and re-install.

High temperature, steam-cleaning methods should not be used with the polypropylene filters due to the temperature limitations.

#### **NOTICE**

Do not operate the WSO mist collector without the first-stage filter in place. Significant reduction in primary filter life can result.

### Primary Filter

Note: With the collector's airflow off, allow mist-laden, wet filter to drain into the inlet plenum for at least 15 minutes prior to removal.

1. Remove the filter by pulling the filter retention lever down to a horizontal position. Remove filter from collector and dispose of properly for the materials collected.

Note: A large plastic garbage bag placed over the top of the used filter allows cleaner filter change out. The filter can be tipped forward and out of the collector while the bag is pulled up over the bottom of the cartridge.

2. Place new filter on the filter retention platform, gasket side up. Slide filter back as far as it will go.

Note: The primary filter must be replaced. Do not wash.

3. Lift the filter retention lever up and close access door.

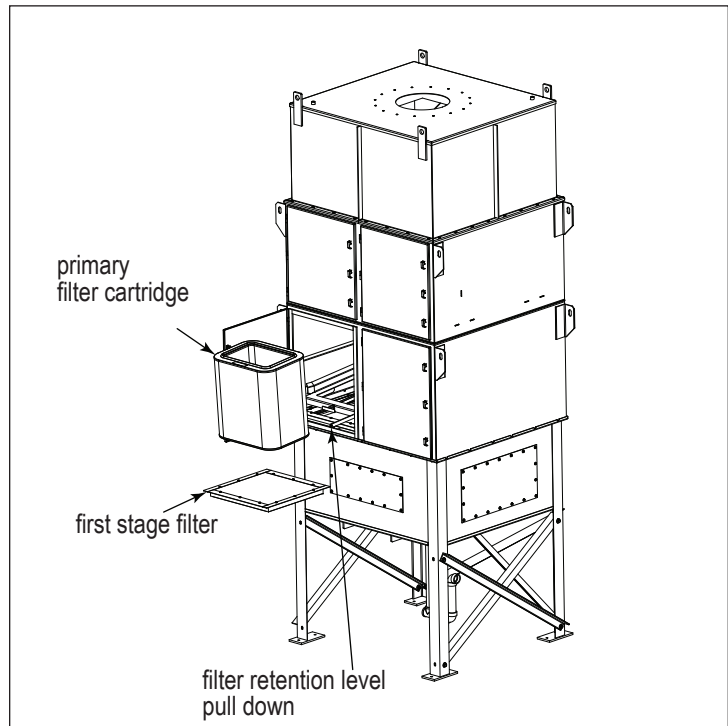

Primary Filter Replacement, WSO 25-4 shown

## Final Filter

Note: The final filter must be replaced. Do not wash.

1. Open the final filter access door and lower the retention handles to release the filter.
2. Remove the filter and dispose of properly for the materials collected.

**NOTICE**

Dirty filters may be heavier than they appear. Provide a support platform or have two people, one on each side of the filter and pull the filter out.

3. Install the replacement filter gasket-side up.
4. Seal the filter in place by lifting the retention handles to the upright position.

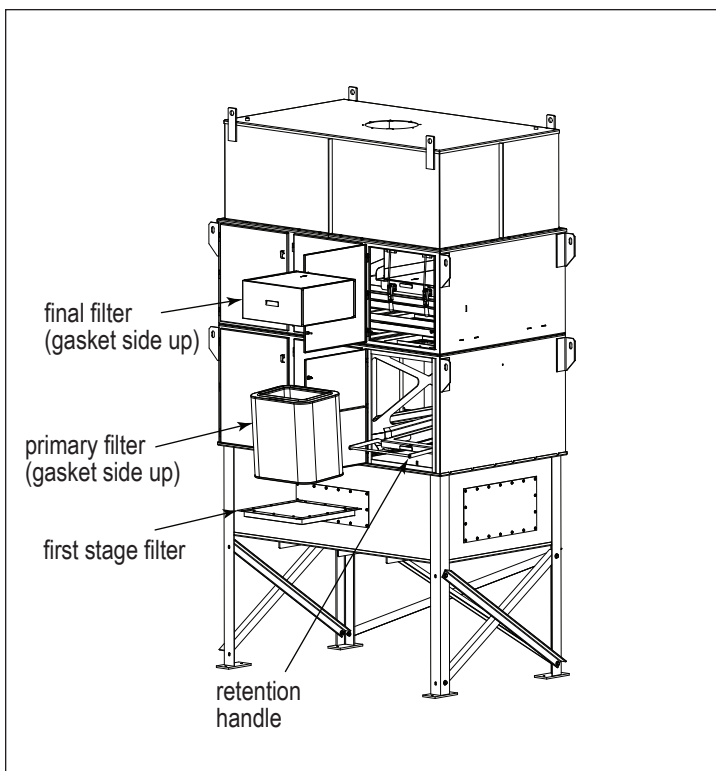

Final Filter Installation, Powered WSO 25-6 shown

## P-Trap Service

1. Place a suitable container under the P-Trap, turn the collector OFF and remove the pipe plug.
2. Allow fluid and particulate to drain.
3. Use thread sealant and replace pipe plug.
4. Refill the P-Trap with suitable fluid before restarting the collector.

## P-Trap with Y-Strainer, Screen Cleaning and Removal

1. Place a suitable container under the screen clean-out valve, turn the collector OFF, close the P-Trap valve, then open the screen clean-out valve.
2. Allow fluid and particulate to drain.
3. With the clean-out valve open, slowly open the P-Trap valve. This allows fluid still trapped in the hopper to drain.

### NOTICE

A substantial amount of fluid may be trapped in the hopper and could exceed the container capacity. Open the P-Trap valve slowly.

4. Close the P-Trap valve.
5. Unscrew the screen cap and pull the screen out.
6. Clean the screen and the inside of the Y-strainer body and re-assemble taking care to seat the screen in the body and cap.
7. Close the clean-out valve.
8. Open the P-Trap valve.
9. Refill the P-Trap with suitable fluid before restarting the collector.

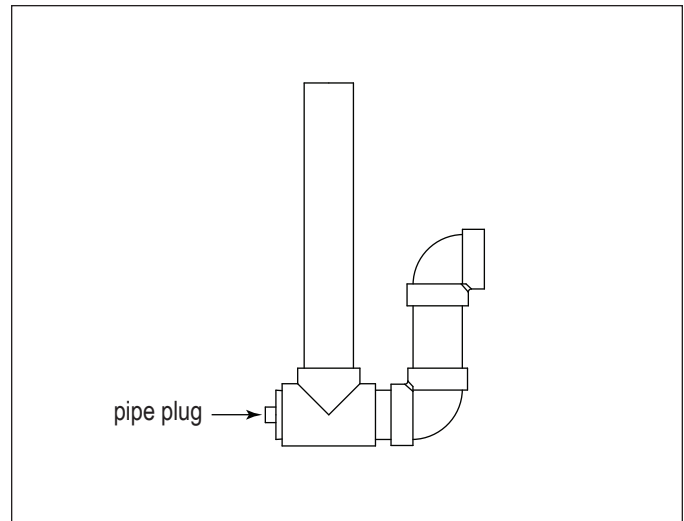

P-Trap

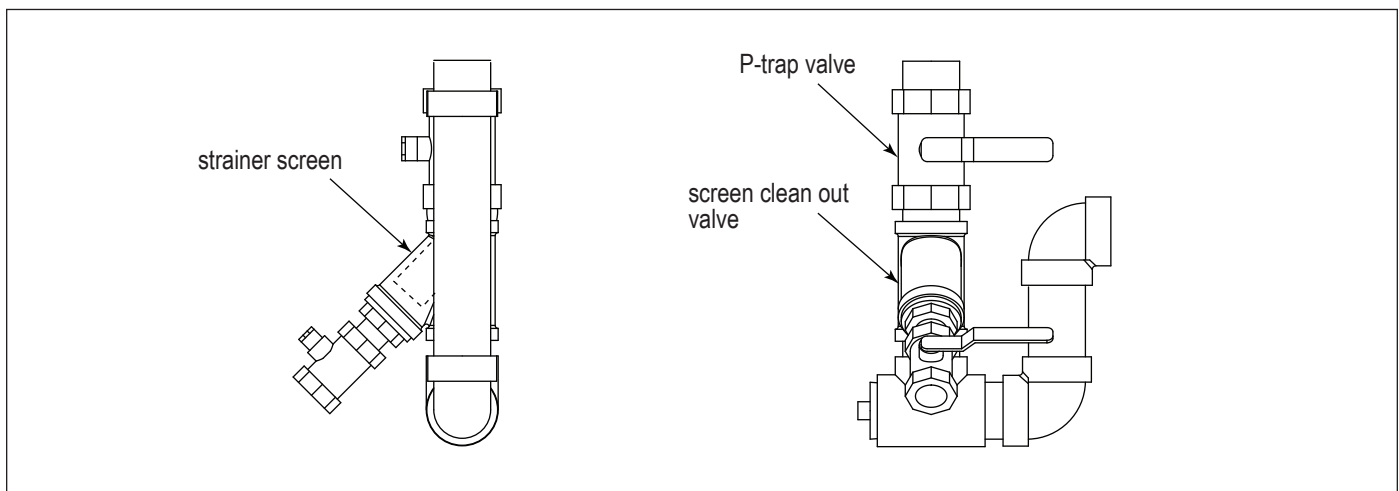

P-Trap with Y-Strainer

## Options and Accessories



Failure to lift the fan correctly can result in severe personal injury and/or property damage.

Use appropriate lifting equipment and adopt all safety precautions needed for moving and handling the fan.

Only qualified crane or forklift operators should be allowed to lift equipment.

To avoid personal injury and/or damage to equipment, ensure fan blowers are properly attached to equipment.

### NOTICE

The use of a damper or variable frequency drive (VFD) is required to control airflow through the collector. Lack of a control damper or VFD will shorten filter life.

## Fan Controls

The WSO 25-4 and 25-6 can be powered or un-powered..

Powered collectors may use TBI-3-30 Hp Fans and TRB 3-15 Hp Fans.

The collector can accept direct mounted fan blowers, Torit Backward Inclined (TBI) or Torit Radial Blade (TRB), to the top or side of the collector.

For complete information, see the most current version of the TBI or TRB Fan Installation, Operation and Maintenance manual.

## Drain Collection Container

1. Install the drain collection container during installation or after collector is in its' final operating position.
2. Turn collector OFF.
3. Remove the container by unscrewing the container from the cap. Clean the container, faucet, and re-install.

Note: Close the faucet before turning the collector back ON.

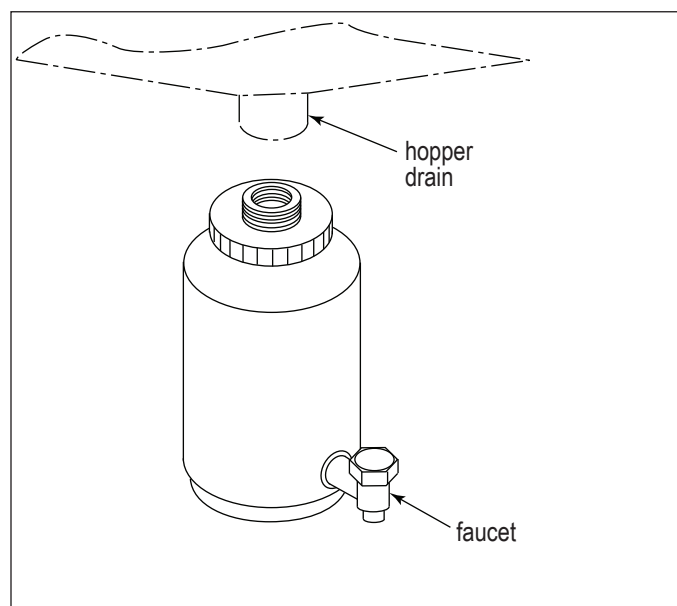

Drain Collection Container

## Troubleshooting

Problem	Probable Cause	Remedy
<b>Fan blower and motor do not start</b>	Improper motor wire size	Rewire using the correct wire gauge as specified by national and local codes.
	Not wired correctly	Check and correct motor wiring for supply voltage. See motor manufacturer's wiring diagram. Follow wiring diagram and the National Electric Code.
	Collector not wired for available voltage	Correct wiring for proper supply voltage.
	Input circuit down	Check power supply to motor circuit on all leads.
	Electrical supply circuit down	Check power supply circuit for proper voltage. Check for fuse or circuit breaker fault. Replace as necessary.
	Overload relay tripped	Reset. Check amp draw on motor leads.
	Defective overload heater or overload assembly	Replace as necessary.
<b>Blower and motor start, but do not stay running</b>	Incorrect motor starter installed	Check for proper motor starter and replace if necessary.
	Access doors are open or not closed tight	Close and tighten access doors. See Filter Installation.
	Electrical circuit overload	Check that the power supply circuit has sufficient power to run all equipment.
<b>Clean-air outlet discharging oil mist</b>	Filters not installed correctly	See Filter Installation.
	Filter damage, dents in the end caps, gasket damage, or holes in media	Replace filters as necessary. Use only genuine Donaldson replacement parts. See Filter Installation.
<b>Insufficient airflow</b>	Fan rotation backwards	Proper fan rotation is clockwise from the top of the collector. The fan can be viewed through the back of the motor. See Preliminary Start-Up Check.
	Access doors open or not closed tight	Check that all access doors are in place and secured.
	Fan exhaust area restricted	Check fan exhaust area for obstructions. Remove material or debris.
	First Stage filter plugged	Remove and clean or replace.
	Primary filter needs replacement	Replace filters as necessary. Use only genuine Donaldson replacement parts. See Filter Installation.
	Plugged HEPA filter	Replace filters as necessary. Use only genuine Donaldson replacement parts. See Optional Equipment.

<b>Problem</b>	<b>Probable Cause</b>	<b>Remedy</b>
<b>Insufficient hopper discharge</b>	Plugged hopper screen	Remove and clean hopper screen.
	Plugged P-Trap	Clean P-Trap. See P-Trap Service.
<b>Liquid leaking from collector door</b>	Plugged P-Trap	Clean P-Trap. See P-Trap Service.
	Plugged or full drain collection container	Remove and clean or empty the drain collection container.

# **Appendix A - Installation**

## Installation



Electrical Installation (including bonding and grounding of the collector) must be performed by a qualified electrician.

This equipment is not designed to support site ducts, piping, or electrical services. All ducts, piping, or electrical services must be adequately supported to prevent injury and/or property damage.

Do not install in classified hazardous atmospheres without an enclosure rated for the application.

Service must be performed by trained and qualified maintenance personnel.

This equipment may start or stop unexpectedly from a remote location

Equipment may reach peak sound pressure levels above 80 dB (A). Noise levels should be considered when selecting equipment location.

## Location and Site Selection



Codes may regulate recirculating filtered air in your facility. Consult with the appropriate authorities having jurisdiction to ensure compliance with all national and local codes regarding recirculating filtered air.

Equipment location must conform to all codes and standards, should be suitable for the type of dust being handled and should ensure easy access for service and utility connections. Site selection must account for wind, seismic zone and other load conditions. Collector intended for indoor installation and can be located on a foundation, structural framing, suspended or hung from overhead supports.

The equipment must be anchored once in final position. Consult a qualified engineer for final selection of foundation or support framing.

Note: Ensure the inlet has at least five diameters of straight duct prior to the collector inlet including a transition to the full inlet dimensions. Inlet transition should have a taper with a maximum of a 90-degree included angle.

## Provisional Anchor Bolt Recommendations

The quantity of anchor bolts should match the number of holes provided in the base plates of the collector. Anchor diameter is typically 1/8-inch less than the baseplate hole diameter. Anchors should project a minimum of 1 3/4 -inch and account for nut, washer, baseplate, and shims/grout.

## Delivery and Inspection

Upon arrival inspect equipment and report any damage to delivery carrier. File any damage claims with the delivery carrier. Request a written inspection report from the Claims Inspector to substantiate all damage claims.

Compare the equipment received with the description of product ordered. Report any incomplete shipments to the delivery carrier and your Donaldson Torit representative.

## Unloading and Positioning



Equipment should be lifted only by qualified crane or fork truck operators.

Failure to lift the equipment correctly can result in severe personal injury and/or property damage.

1. Remove any crates or shipping straps.
2. Lift the packaged collector from transport container.
3. Inspect for any damage and/or missing parts and report to freight carrier.
4. Check for any hardware which may have become loose during shipment and tighten as necessary.

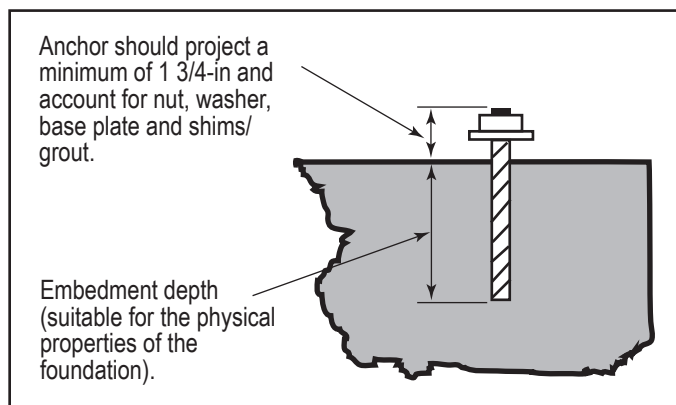

Typical Foundation Anchor

## Lifting Information



Failure to lift the equipment or sub-assemblies correctly can result in severe personal injury and/or property damage.

Only qualified crane or forklift operators should be allowed to lift equipment.

1. Use all lifting points provided.
2. Use clevis connectors, not hooks, on lifting slings.
3. Use spreader bars to prevent damage to equipment.
4. Check the Specification Control drawing for weight and dimensions of the collector and components to ensure adequate crane capacity.
5. Lift collector and accessories separately and assemble after collector is in place.
6. Use drift pins to align holes in section flanges during assembly.

## Support Installation



Anchors must comply with local code requirements and be capable of supporting dead, live, wind, seismic and other applicable loads.

Anchor sizes shown are provisional, as final anchor sizing will depend on jobsite load conditions, equipment location, foundation/framing design variables and local codes.

Consult a qualified engineer for final selection of suitable anchors.

Reference typical leg assembly drawing shipped with the collector prior to starting assembly.

Prepare the foundation or support framing in the selected location. Locate and install anchors.

## Electrical Wiring



Electrical installation, service, or maintenance work must be performed by a qualified electrician and comply with all applicable national and local codes.

This equipment may start or stop unexpectedly from a remote location.

Turn power off and lock out all power before performing service or maintenance work.

The appropriate wiring schematic and electrical rating must be used. See collector's rating plate for required voltage.

Do not install in classified hazardous atmospheres without an enclosure rated for the application.

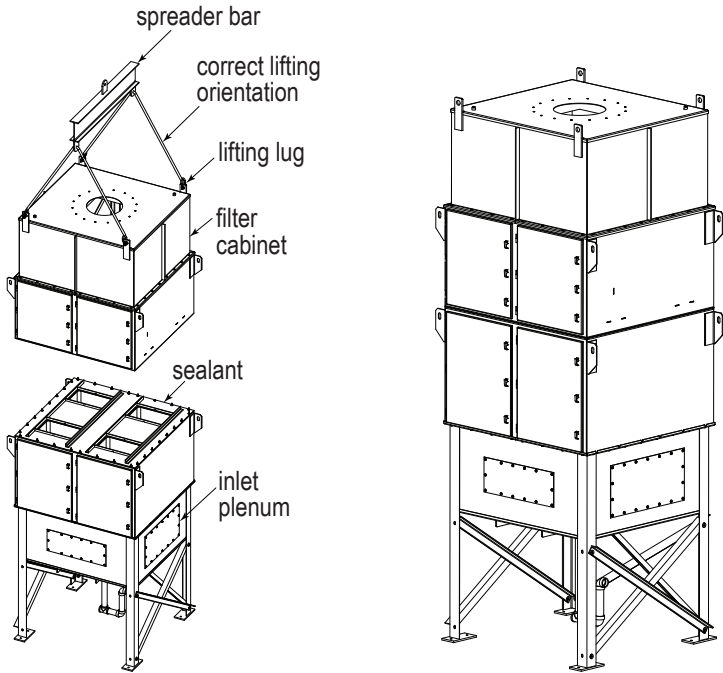
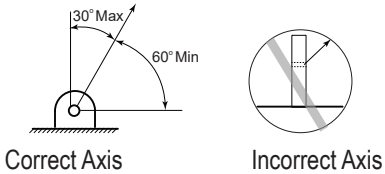

Typical Lifting Guidance | WSO 25-4 shown

## P-Trap Installation

### NOTICE

Ensure collected material properly flows through the P-Trap. The P-Trap dimensions should accommodate a column of coolant greater than the static capacity of the fan to avoid coolant pooling in the collector and potentially causing property damage.

1. Install the P-Trap as shown in P-Trap Installation.
2. Position the P-Trap outlet to the proper location and tighten the union.
3. Plumb the P-Trap to a receptacle or install a return line back to the machine center.
4. Fill P-Trap before starting collector.

Note: The characteristics of some machining fluids change with time, use, and exposure to air. Check the condition of the collected fluid before re-using.

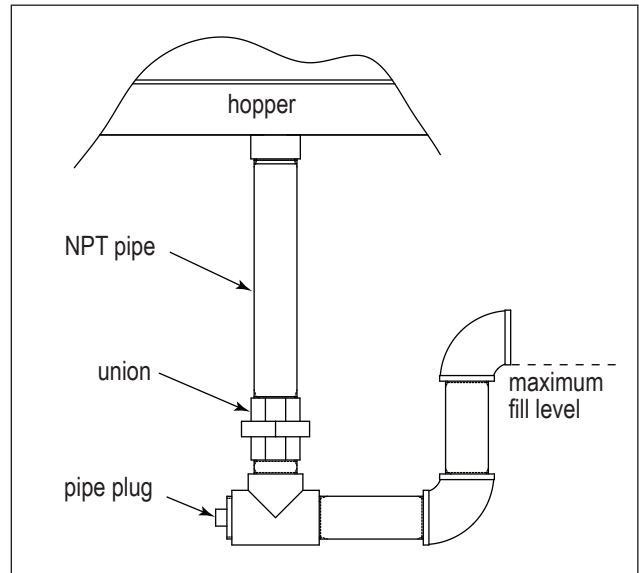

P-Trap Installation

## Inlet Plenum Installation

Reference Typical Foundation Anchor and leg assembly drawing shipped with the collector prior to starting assembly.

1. Prepare the foundation or support framing in the selected location. Locate and install anchors.
2. Using a crane or forklift, raise the inlet plenum to the required height.
 

Note: When using a crane, use clevis pins and a sling attached to four lifting lugs.
3. Lower the inlet plenum with legs to the anchor bolts.
4. Level inlet plenum and secure all hardware.
5. Apply supplied sealant to the top flange of the inlet plenum.
6. Remove the first stage and primary filters from the filter cabinet and set aside.
7. Using a crane or forklift, raise the filter cabinet section to the required height. See below illustration for correct lifting orientation.
8. Set cabinet on top of the inlet plenum flange and attach with the supplied fasteners.
9. Remove crane or forklift.
10. Re-install the first stage and primary filters.

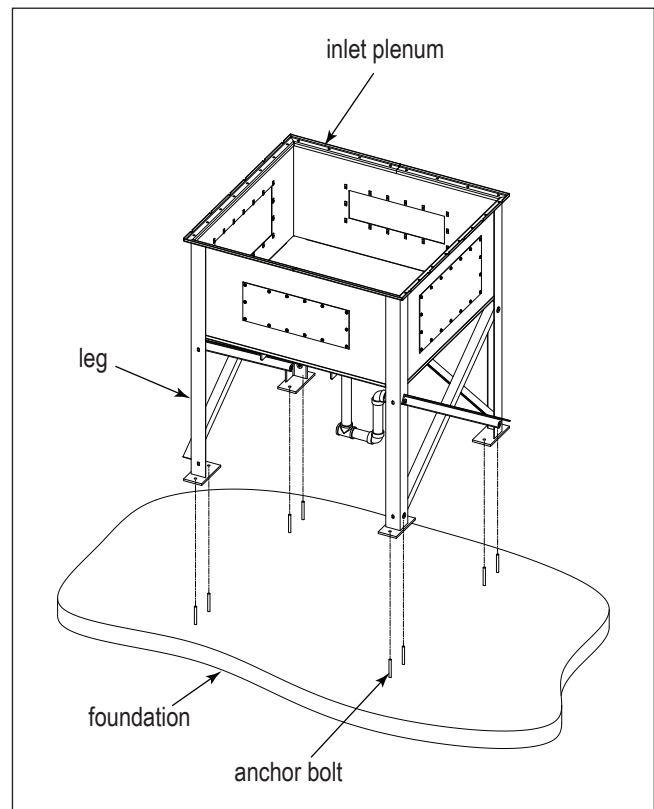

Inlet Plenum Installation, WSO 25-4 shown

## Options and Accessories

### Cleaning Controls and Sensors

#### Magnehelic Installation

1. Choose a convenient, accessible location on or near the collector for mounting that provides the best visual advantage.
2. Mount the pressure tap hardware on the clean-air plenum panel.
3. Plug the pressure ports on the back of the gauge using two, 1/8-in NPT pipe plugs supplied. Install two, 1/8-in NPT male adapters supplied with the gauge into the high- and low-pressure ports on the side of the gauges.
4. Attach the mounting bracket using three, #6-32 x 1/4-in screws supplied.
5. Mount the gauge and bracket assembly to the supporting structure using two, self-drilling screws.
6. Thirty-five feet of plastic tubing is supplied and must be cut in two sections. Connect one section of tubing from the gauge's high-pressure port to the pressure fitting located in the dirty-air plenum. Connect remaining tubing from the gauge's low-pressure port to the fitting in the clean-air plenum. Additional tubing can be ordered from your representative.
7. Carefully remove the cloth protecting the filters. Close access doors and tighten securely by hand.
8. Zero and maintain the gauge as directed in the manufacturer's Operating and Maintenance Instructions provided.

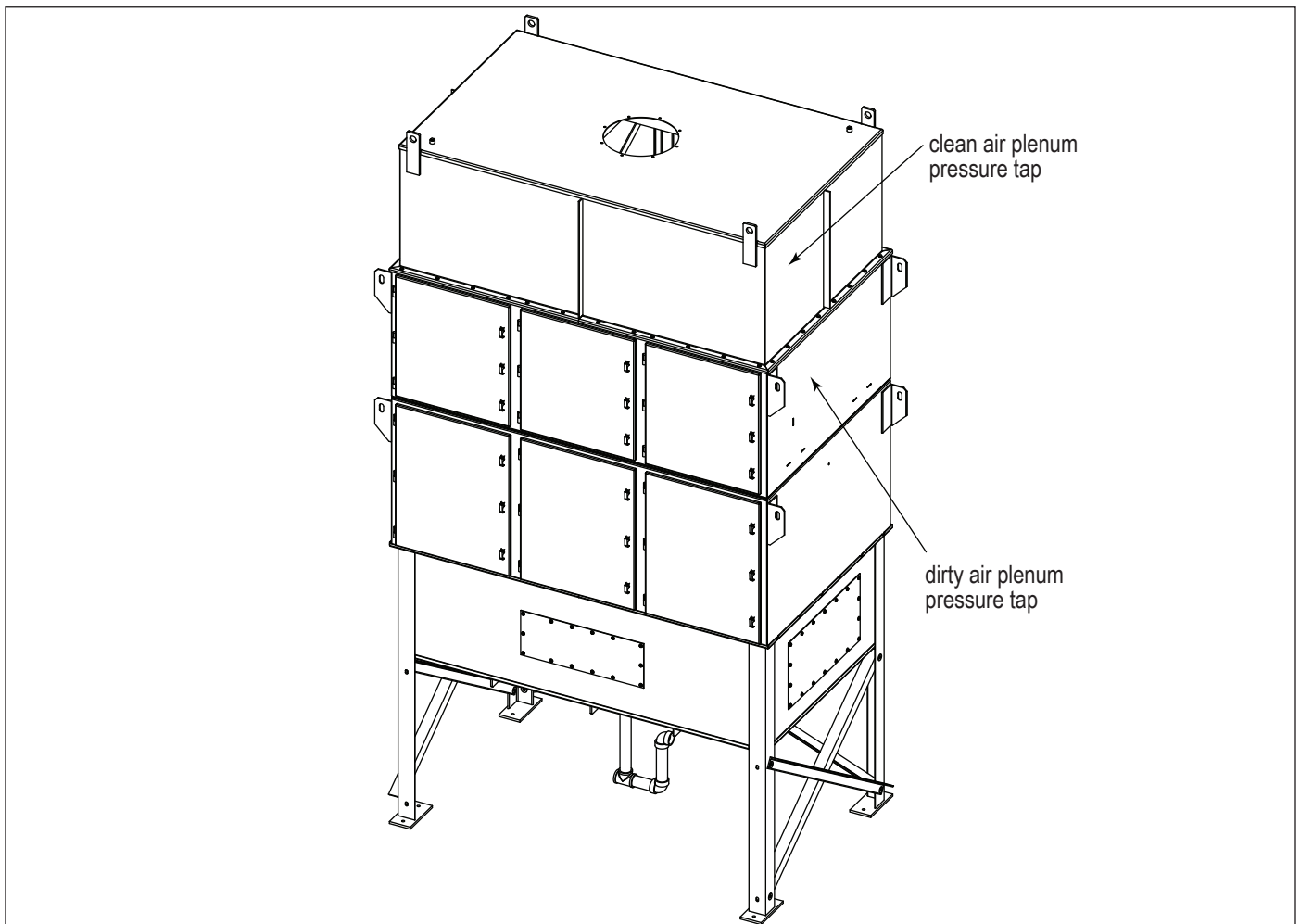

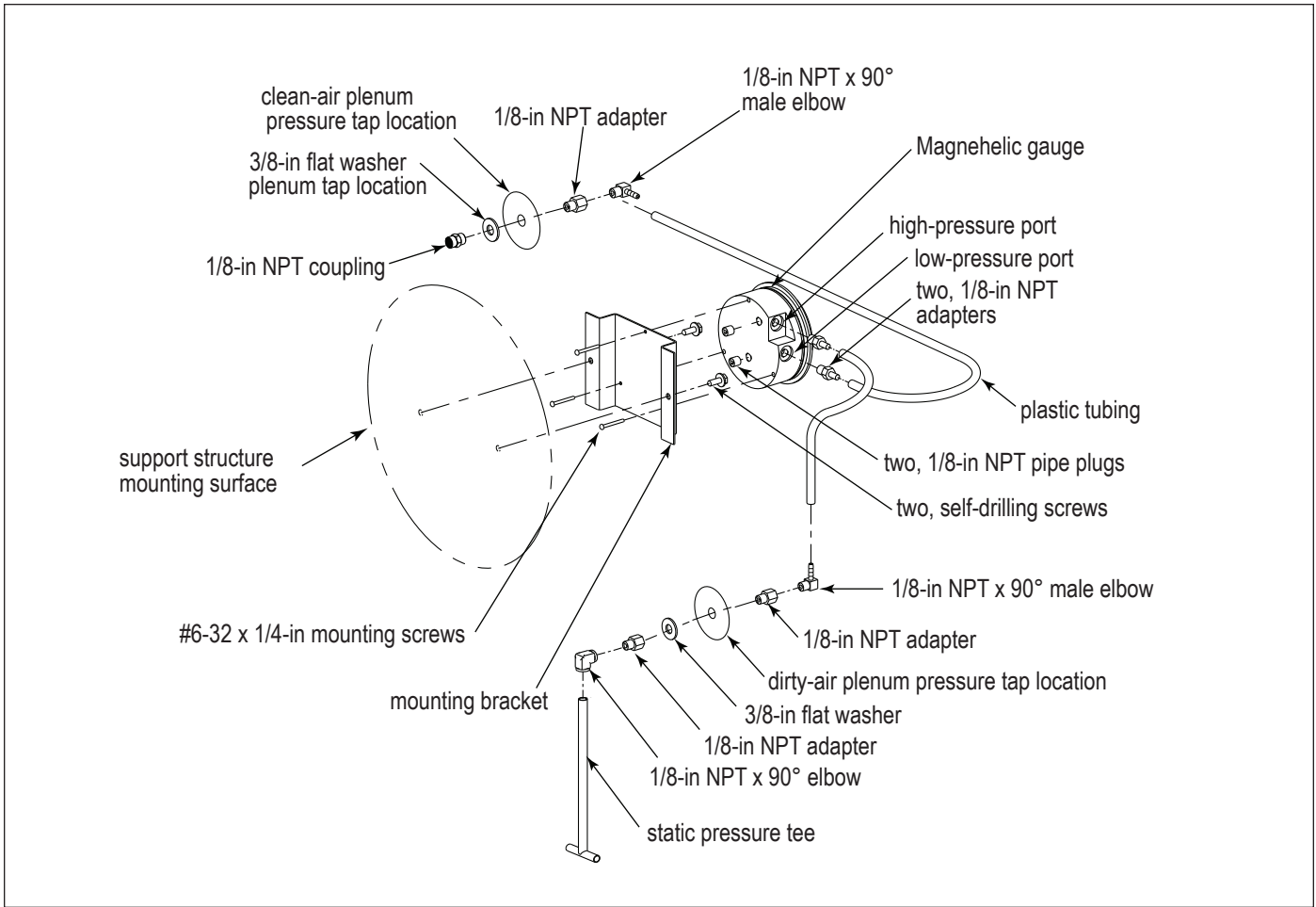

Magnehelic Gauge

## Damper and Silencer, TBI (WSO Unpowered 25-4 and 25-6)

### Top Mount

1. Install the blower and motor as shown below.
2. Attach the damper to the blower exhaust outlet using the hardware supplied.
3. Attach the flange to the damper using the bolts, washers, and hex nuts supplied.
4. Apply sealant to the flange and attach silencer to flange. Tighten all hardware.
5. Loosely assemble the silencer's support brackets.

### Support Brackets, Top Mount

- a. Align the pivoting support brackets to extend a minimum of 30-in from the collector and mark the drill locations.



Thoroughly clean any collected coolants or material from the collector prior to drilling to reduce the risk of combustion. Failure to comply may result in personal injury and/or property damage.

- b. Drill pilot holes with a 0.339-in bit.
- c. Secure brackets using 3/8-in thread-forming bolts.
- d. If a gap exists between the silencer and the damper, install the panel filler using the screws provided.

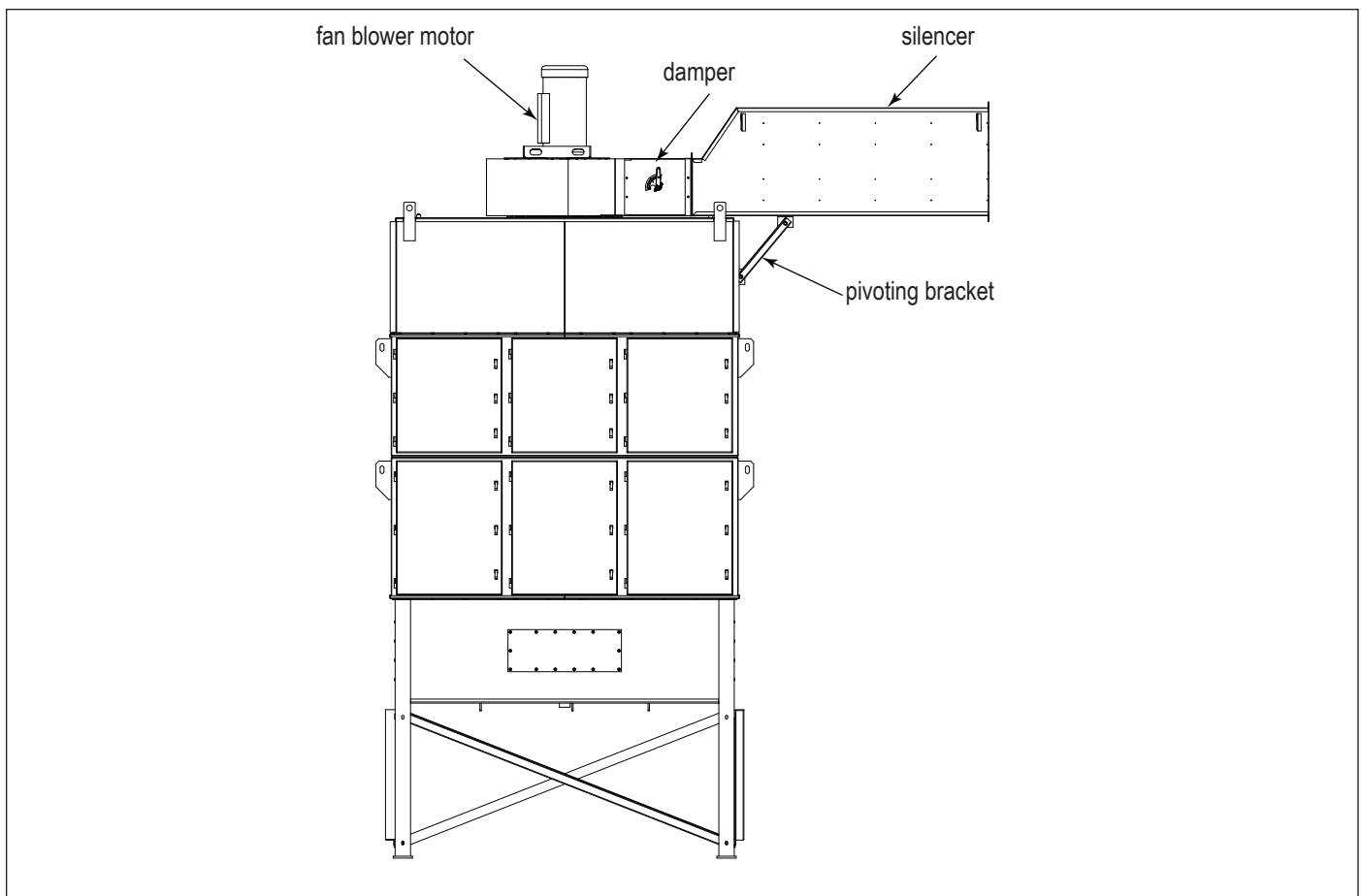

Top-Mount Silencer and Damper Installation, WSO Unpowered 25-6 shown

## Sprinkler Coupling



Sprinklers can place a large quantity of water in the dust collector when activated. Provide adequate drainage to remove water. Excess water weight can cause the leg structure to collapse.

Consult with local authorities when installing fire control systems on dust collection equipment.

### ***NOTICE***

Sprinkler couplings are provided for the convenience of fire control system installers. The fire control system installer shall make their own decisions on the appropriate location of fire control system components.

WSO collectors must be equipped with a customer-supplied safety disconnect with short circuit protection, contactors, and overload protection. Complete the wiring as shown in Motor Starter Wiring.

### Pre-Wired Collectors

Pre-wired collectors include contactors and overload protection and requires a customer supplied safety disconnect switch. Complete the wiring as shown in Motor Starter Wiring.

### Unwired Collectors

1. Remove the exhaust pack. Remove all bolts and lift starting at one corner.

**NOTICE**

The gasket material is fragile and must be handled with care. If the gasket is disrupted, reposition evenly around the inner and outer flanges when replacing the exhaust panel.

2. Make the wiring connections to the fan motor according to the wiring diagram located inside the control box and the instructions on the motor decal.

**NOTICE**

All electrical components must be sized for the supply voltage and motor horsepower. See Motor Starter Wiring.

3. Reinstall exhaust pack.
4. Turn the fan-motor ON then OFF and check for proper rotation by viewing through the opening on top of the collector.

To reverse rotation, single-phase power supply:  
Follow manufacturer's instructions on the motor's nameplate.

To reverse rotation, three-phase power supply:  
Switch any two leads on the motor junction box.



Check that the exhaust plenum is free of tools or debris before checking fan rotation.

Stand clear of exhaust to avoid personal injury.

Do not interchange a power lead with the ground wire. Severe personal injury and/or property damage may result.

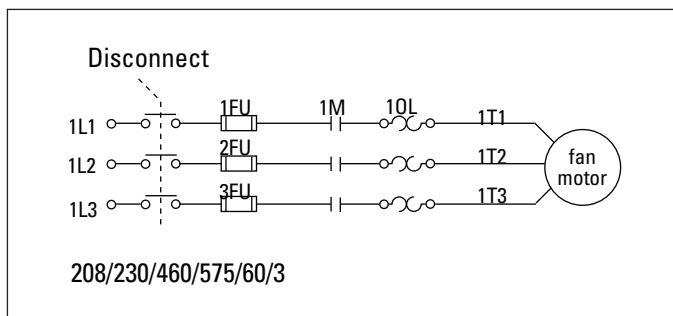

Motor Starter Wiring

## Start-up / Commissioning

Once the WSO has been placed, anchored, connected to power and ducts attached to the appropriate equipment, the collector is ready for initial start-up and commissioning.

Instruct all personnel on safe use and maintenance procedures.



Electrical installation, service, or maintenance work must be performed by a qualified electrician and comply with all applicable national and local codes. This equipment may start or stop unexpectedly from a remote location.

Turn power off and lock out all power before performing service or maintenance work.

Turn compressed air supply OFF, bleed and lock out lines before performing service or maintenance work.

Check that the collector is clear and free of all debris before starting.

Do not install in classified hazardous atmospheres without an enclosure rated for the application.

## Motor Starter Control Box

Mount the motor starter control box in a convenient location.

1. Using the wiring diagram supplied inside the control box and the instructions on the motor decal, make the connections to the blower motor.

Note: If the collector is supplied with an optional junction box, wire the motor starter to the terminal strip located inside the junction box according to the wiring diagram supplied with the junction box.

2. Check all electrical connections for tightness and contact.
3. Check for proper rotation on all motors as described below.



Do not look into fan outlet to determine rotation. View the fan rotation through the back of the motor.

Check that the exhaust plenum is free of tools or debris before checking fan rotation.

Stand clear of exhaust to avoid personal injury.

Do not interchange a power lead with the ground wire. Severe personal injury and/or property damage may result.

- a. Bump the fan to initiate rotation.
  - b. As the fan is winding down (unpowered) compare fan rotation to the rotation label (located on fan housing) direction.
4. If the fan rotation is reversed, correct the rotation.

To reverse rotation, single-phase power supply: Follow manufacturer's instructions on the motor's nameplate.

To reverse rotation, three-phase power supply: Switch any two leads on the motor junction box.

- a. Turn off the collector and Lock-Out all energy sources.
- b. Within the junction box, swap the connection location of two power leads on the terminal block, making certain not to swap a power lead and the ground wire.



Do not interchange a power lead with a ground wire or severe personal injury and/or property damage may result.

5. Check that all filters are properly installed.
6. Ensure all equipment access panels are sealed and secure.
7. Check and remove all loose items in or near the inlet and outlet of the collector.
8. Check that all remote controls are properly wired and all service switches are in the OFF position.
9. Check that all optional accessories are installed properly and secured.
10. Fill P-Trap if equipped or close faucet valve on drain collection container if used.
11. Turn power ON at source.

## Decommissioning Collector

Once the collector has reached the end of operational life it will need to be decommissioned.



During decommissioning, there is a potential for exposure to the mist in the collector. Most mists present safety and health hazards that require precautions. Wear eye, respiratory, head and other protection equipment suitable for the type of mist when performing any decommissioning activities.

LOCK-OUT all energy sources prior to performing any decommissioning activities on the equipment.

Electrical service must be performed by a qualified electrician.

Disconnection of ducts must be performed by a qualified tinsmith or contractor.

1. Turn off the collector and Lock-Out all energy sources.
2. Remove all filters from the collector and dispose of in a suitable fashion for the mist in the collector (See Filter Replacement for instructions). Close and secure front access doors after filters are removed.
3. Disconnect electrical power from the collector and remove any associated conduit or hardware from the exterior of the collector.
4. Seal the inlet and discharge openings of the collector with shipping covers to prevent residual dust from migrating from the collector during transport for disposal.
5. Remove anchor bolts and hardware from the collector.
6. Pick up the collector and place in a location suitable to prepare it for transportation. (See Lifting Information for lifting guidance.)
7. Secure the collector to a suitable transport carrier and transport to a disposal site suitable for the mist in the collector.

**Product Information** (Process Owner to complete and retain for your records)

Model Number _____	Serial Number _____
Ship Date _____	Installation Date _____
Filter Type _____	
Collected Dust _____	
Dust Properties: Kst _____	Pmax _____ MIE _____ MEC _____
Accessories _____	
Other _____	
_____	





## Donaldson Industrial Air Filtration Warranty

Donaldson warrants to the original purchaser only that the Goods will be free from defects in material and manufacture for the applicable time periods stated below: (1) Major structural components for a period of ten (10) years from the date of shipment; (2) Non-Structural, Donaldson-built components and accessories including Donaldson Airlocks, TBI Fans, TRB Fans, Fume Collector products, Donaldson built electrical control components, and Donaldson-built Afterfilter housings for a period of twelve (12) months from date of shipment; and (3) Donaldson-built filter elements for a period of eighteen (18) months from date of shipment.

Buyer is solely responsible for determining if goods fit Buyer's particular purpose and are suitable for Buyer's process and application. Seller's statements, engineering and technical information, and recommendations are provided for the Buyer's convenience and the accuracy or completeness thereof is not warranted. If, after Seller receives written notice, within the warranty period, that any goods allegedly do not meet Seller's warranty, and Seller, in its sole discretion, determines that such claim is valid, Seller's sole obligation and Buyer's exclusive remedy for breach of the foregoing warranty or any Seller published warranty, will be, at Seller's option, either: (i) repair or replacement of such goods or (ii) credit or refund to Buyer for the purchase price from Seller. In the case of repair or replacement, Seller will be responsible for the cost of shipping the parts but not for labor to remove, repair, replace or reinstall the allegedly defective goods. Refurbished goods may be used to repair or replace the goods and the warranty on such repaired or replaced goods shall be the balance of the warranty remaining on the goods which were repaired or replaced. Any repair or rework made by anyone other than Seller is not permitted without prior written authorization by Seller, and voids the warranty set forth herein. Seller warrants to Buyer that it will perform services in accordance with the Sales Documents using personnel of required skill, experience and qualifications and in a professional and workmanlike manner in accordance with generally recognized industry standards for similar services. With respect to any services subject to a claim under the warranty set forth above, Seller shall, in its sole discretion, (i) repair or re-perform the applicable services or (ii) credit or refund the price of such services at the pro rata contract rate and such shall be Seller's sole obligation and the exclusive remedy for breach of the foregoing warranty on services. Products manufactured by a third party ("Third Party Product") may constitute, contain, be contained in, incorporated into, attached to or packaged together with, the goods. Buyer agrees that: (a) Third Party Products are excluded from Seller's warranty in this Section 7 and carry only the warranty extended by the original manufacturer, and (b) Seller's liability in all cases is limited to goods of Seller's design and manufacture only. EXCEPT FOR SELLER'S WARRANTY OF TITLE TO THE GOODS, SELLER EXPRESSLY DISCLAIMS AND EXCLUDES ALL OTHER WARRANTIES WHATSOEVER, WHETHER, EXPRESSED OR IMPLIED, ORAL, STATUTORY, OR OTHERWISE, INCLUDING BUT NOT LIMITED TO MERCHANTABILITY, FITNESS FOR A PARTICULAR PURPOSE, NON-INFRINGEMENT OF THIRD PARTY INTELLECTUAL PROPERTY AND ANY WARRANTIES ARISING FROM TECHNICAL ADVICE OR RECOMMENDATIONS, COURSE OF DEALING OR OF PERFORMANCE, CUSTOM OR USAGE OF TRADE. Seller's obligations do not cover normal wear and tear or deterioration, defects in or damage to any goods resulting from improper installation, accident or any utilization, maintenance, repair or modification of the goods, or any use that is inconsistent with Seller's instructions as to the storage, installation, commissioning or use of the goods or the designed capabilities of the goods or that, in its sole judgment, the performance or reliability thereof is adversely affected thereby, or which is subjected to abuse, mishandling, misuse or neglect or any damage caused by connections, interfacing or use in unforeseen or unintended environments or any other cause not the sole fault of Seller, and shall be at Buyer's expense. Seller's warranty is contingent upon the accuracy of all information provided by Buyer. Any changes to or inaccuracies in any information or data provided by Buyer voids this warranty. Seller does not warrant that the operation of the goods will be uninterrupted or error-free, that the functions of the goods will meet Buyer's or its customer's requirements unless specifically agreed to, or that the goods will operate in combination with other products selected by Buyer or Buyer's customer for its use.

The terms of this warranty may only be modified by a special warranty document signed by a Director, General Manager or Vice President of Donaldson. To ensure proper operational performance of your equipment, use only genuine Donaldson replacement parts.

**This Product is provided subject to and conditioned upon Donaldson's Terms of Sale ("Terms"), a current copy of which is located at [termsofsale.donaldson.com](http://termsofsale.donaldson.com). These Terms are incorporated herein by reference. By purchasing or using this Product, the user accepts these Terms. The Terms are available on our website or by calling our customer service line at 1-800-365-1331.**

Significantly improve the performance of your collector with genuine Donaldson Torit replacement filters and parts.

---

**Important Notice:** Many factors beyond the control of Donaldson can affect the use and performance of Donaldson products in a particular application, including the conditions under which the product is used. Since these factors are uniquely within the user's knowledge and control, it is essential the user evaluate the products to determine whether the product is fit for the particular purpose and suitable for the user's application. All products, product specifications, availability and data are subject to change without notice, and may vary by region or country.



Donaldson.

## Craig Equipment Company

13055 MIDDLETOWN INDUSTRIAL BLVD. LOUISVILLE, KY 40223 • P.O. BOX 43250 LOUISVILLE, KY 40253  
TF:800-928-7100 • T:502-245-4840 • F:502-245-1665 [craig-equip.com](http://craig-equip.com)