

# VIGILEX®

SAFETY PROTECTION

By **stir**

## VIGIFLAP EXPLOSION ISOLATION VALVE

2023 - FIRST EDITION - VERSION 0010



# REVISION CHANGE LOG

## VERSION 10: 12/2023

- Added sizes 4"-5"
- Added additional Vigiflap Specifications
- Added increased details and diagrams of locking mechanism
- Added section explaining Floating vs Locked settings
- Added Pressure Drop Tables
- Added Locking Mechanism for >34"
- Removed discontinued CP04 section
- Added Maintenance section
- Added Appendix with wiring schematics and diagrams

## VERSION 9: 05/2023

- Added sizes > 32"
- Added Vigiflap Specifications section
- Re-organized Certification Specifications
- Revised Mounting Sensors section

## VERSION 8: 01/2023

- Transferred from the EcoMAXX product line to the Vigilex product line
- Added Floating Flap section
- Updated Locking Mechanism section
- Added CP05 option
- Removed discontinued CP03 option and wiring information for CP03

## TABLE OF CONTENTS

SAFETY AND WARRANTY INFORMATION	4
INTRODUCTION AND NFPA COMPLIANCE	5
VIGILEX VIGIFLAP SPECIFICATIONS	6
SPECIFICATIONS FOR SIZES 4”-32”	7
SPECIFICATIONS FOR SIZES 34”-54”	8
FLOATING VS LOCKED OPEN POSITIONS	9
POSSIBLE CONFIGURATIONS	10
VIGIFLAP (VF) DIMENSIONS (DUCT Ø 4” TO 32”)	14
VIGIFLAP (VF) DIMENSIONS (DUCT Ø 34” TO 54”)	15
VIGIFLAP (VF) PRESSURE DROP	17
VIGILEX VIGIFLAP LOCKING MECHANISM 4”-32”	23
VIGILEX VIGIFLAP LOCKING MECHANISM FOR > 34”	25
CONTROL PANEL SPECIFICATIONS	27
RECEIVING THE VIGILEX VIGIFLAP	28
MOUNTING SENSORS	29
GENERAL WIRING SCHEMATIC FOR THE CP05	30
BYPASSING THE DUST LEVEL SENSOR	31
FREQUENTLY ASKED QUESTIONS	33
APPENDIX A: WIRING DIAGRAMS	34
APPENDIX B: WIRING GRAPHIC	38
CONTACT INFORMATION	43

# SAFETY AND WARRANTY INFORMATION

## SUPPLEMENTAL MANUAL INFORMATION

This manual is a supplement to the Vigilex installation, use and maintenance manual for the Vigiflap. It has been compiled by Boss Products, LLC® for the North America market. The installer and end user must be familiar with both the Vigilex Manual and the Boss Products supplement.

### SAFETY

#### ELECTRICAL SHOCK HAZARD

ONLY QUALIFIED PERSONNEL SHOULD INSTALL, MAINTAIN OR WORK ON THIS EQUIPMENT!

ALWAYS PERFORM WORK WITH THE POWER OFF.

#### ARC FLASH HAZARD.

APPROPRIATE PPE REQUIRED!

FOLLOW ALL REQUIREMENTS IN NFPA 70E

ALWAYS MAINTAIN PROPER CONVEYING VELOCITIES AS REQUIRED BY NFPA 652 & 654 FOR COMBUSTIBLE DUSTS.

#### WARNING!

DO NOT SUBSTITUTE COMPONENTS.

READ ALL DISCLAIMERS IN THE CORRESPONDING AIREX MANUAL.

IT IS THE INSTALLERS RESPONSIBILITY TO VERIFY THAT THEIR INSTALLATION COMPLIES

WITH REQUIREMENTS SET BY THE AUTHORITY HAVING JURISDICTION:

ALL NATIONAL, LOCAL, NEC, AND NFPA CODES AND/OR GUIDELINES.

### WARRANTY RETURNS

- Pre-qualified Warranty Returns must be shipped freight pre-paid and include an RMA approval document.
- The returned item will be inspected upon its arrival at Boss, Schertz Texas.
- If a replacement item is required before return and inspection, a new purchase order must be placed authorizing shipment of the replacement item.
- The new item will be invoiced and shipped FOB point of origin.
- If the returned item is determined to be under warranty and defective, it will be repaired or replaced at the seller's discretion and returned to the buyer FOB point of origin.

### WARRANTY

- Boss Products, LLC® warrants that the materials sold to a buyer is free from manufacturing defects at the time of shipment.
- Boss Products further warrants to the buyer that the product will remain free of defect for a period of 12 months of shipment on the condition that product has been maintained, installed and operated according to its intended use.
- Furthermore, this warranty will remain in force only as long as the following conditions are documented as being accurately applied.
- Installation and application in compliance of all applicable codes and standards, including National Electric Codes, NFPA recommendations & generally accepted good practice.
- A buyer will be responsible for remedies for defects caused by services not provided by Boss Products.

**THERE ARE NO WARRANTIES EITHER EXPRESSED OR IMPLIED, INCLUDING IMPLIED WARRANTIES OF MERCHANTABILITY AND FITNESS FOR A PARTICULAR PURPOSE, WHICH EXTEND BEYOND THE WARRANTIES SPECIFICALLY CONTAINED IN THIS DOCUMENT. BOSS PRODUCTS, LLC SHALL NOT BE LIABLE FOR ANY INCIDENTAL, CONSEQUENTIAL,**

**DIRECT, INDIRECT OR OTHER DAMAGES ARISING UNDER ANY THEORY OF LAW WHATSOEVER.**



6729 Guada Coma Dr.  
Schertz, TX 78154  
M: 210-664-4200  
F: 210-664-4220  
info@bossproductamerica.com

VF NA SUP. MANUAL 2023 - FIRST EDITION - VERSION 0010  
RELEASE DATE: 12/2023

# INTRODUCTION AND NFPA COMPLIANCE

## INTRODUCTION

Thank you for purchasing the Vigilex Vigiflap (VF). The VF is an Explosion Isolation Device specifically designed to prevent deflagration propagation between connected equipment. Sizes 4” through 32” are ATEX 16447 certified and NFPA 69 compliant. Specifications for sizes above 32” are based on manufacturer’s suggestion.

### REQUIRED ITEMS FOR NFPA 69 COMPLIANCE:

- CP05 Intrinsically Safe Control Panels
- Inductive Proximity Sensor for System Shutdown Upon Flap Closure
- Adjustable Dust Level Sensor to Sense Dust Accumulation in Valve (Metallic or Organic)

## NFPA COMPLIANCE

### NFPA 652 – STANDARD ON THE FUNDAMENTALS OF COMBUSTIBLE DUST - 2019 EDITION

- 9.7.4 – Equipment Isolation
  - o 9.7.4.1\* – Where an explosion hazard exists, isolation devices shall be provided to prevent deflagration propagation between connected equipment in accordance with NFPA 69.
  - o 9.7.4.3 – Isolation of Upstream Work Areas. Where a dust explosion hazard exists, isolation devices shall be provided to prevent deflagration propagation from equipment through upstream ductwork to the work areas in accordance with NFPA 69.

### NFPA 69 – STANDARD OF EXPLOSION PREVENTION SYSTEMS - 2019 EDITION

#### CHAPTER 12 - DEFLAGRATION CONTROL BY PASSIVE ISOLATION

##### o 12.2.3 FLOW ACTUATED FLAP VALVE

The VF meets all requirements of this section when installed with all options and conveying ductwork per 12.2.3.4.6

#### KEY POINTS

- 12.2.3.4.2 Requires a locking mechanism which is provided standard.
- 12.2.3.4.3 Requires an Inspection door which is provided standard.
- 12.2.3.4.4 Requires an immediate, automatic shutdown of the protected process. Accomplished with an inductive proximity sensor which is mounted on the Vigiflap and sends a signal upon an event.
- 12.2.3.4.5 and 12.2.3.4.5.1 requires a continuous signal to ensure valve operation is not compromised by the accumulation of a dust layer on the bottom interior of the valve and requires an immediate, automatic and orderly shutdown of the protected process. Accomplished with an adjustable capacitive style Dust Level Sensor (DLS) which sends a signal when 0.15”-0.20” of dust has accumulated. The DLS is located in the air-stream and requires intrinsically safe wiring.
- 12.2.3.5 Requires System Certification by a recognized testing organization. A.10.4.2.1 allows for European CEN ATEX certification being acceptable.



6729 Guada Coma Dr.  
Schertz, TX 78154  
M: 210-664-4200  
F: 210-664-4220  
info@bossproductamerica.com

# VIGILEX VIGIFLAP SPECIFICATIONS

## (ALL SIZES)

Heavy Duty Welded Steel Construction \* Safety Red Finish (RAL 3020)  
Flanged Inlet and Outlet (Co-Flange Not Included)\* Grounding Lugs \* Locking Mechanism(s)

Kst Max	$\leq 250$ bar.m/s (No Minimum)	$P_{red}$ max	$\leq 0.5$ bar
Pmax	$\leq 10$ bar	Vigiflap Resistance	2.0 bar
MIE	$\geq 10$ mJ	Elbow Quantity	No limit
MIT	$\geq 400$ °C	Air Flow	Push or Pull
Dust Type (4"-32")	Organic, Synthetic, and Metallic	Max Positive Pressure	200 inH2O
Dust Type (34"-54")	Organic and Synthetic	Max Negative Pressure	-321 inH2O

### Working Temperature:

- ◇ Default gasket in EPDM: -22°F to 158°F
  - ◇ Optional gasket in Silicone: 14°F to 356°F
- [Standard sensor is limited to 158°F. Option is available for locking sensor with limit at 302°F]

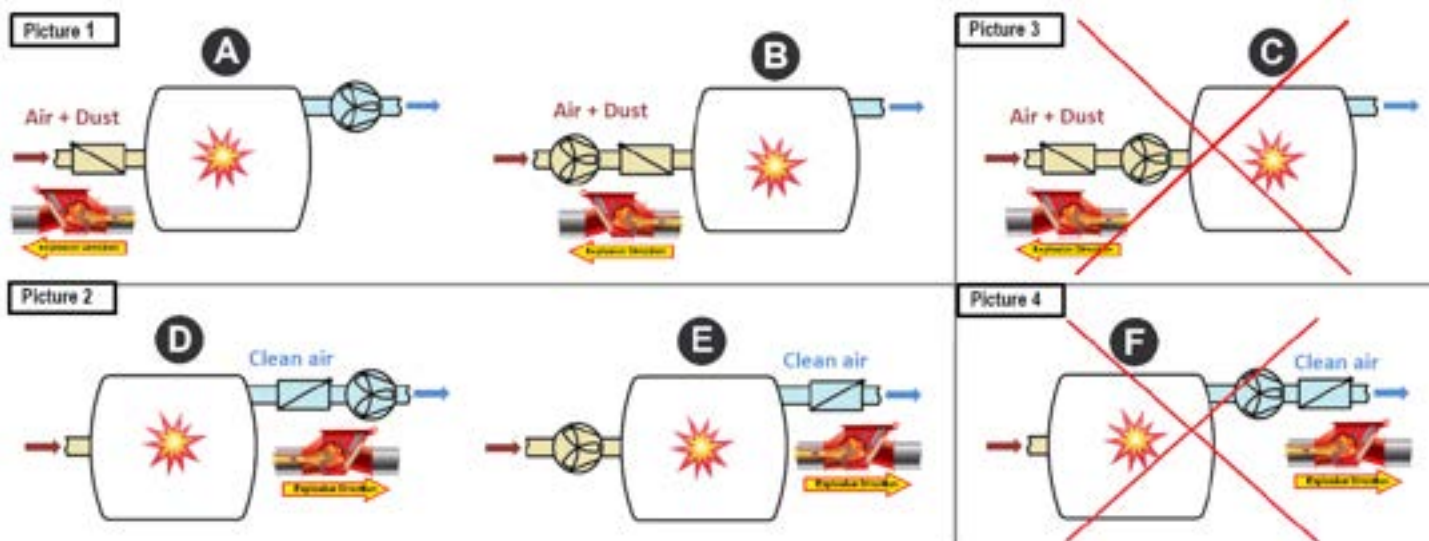

THE VIGIFLAP CAN BE INSTALLED ON EITHER THE CLEAN OR DUST SIDE, SO LONG AS THERE IS NOT A FAN IN BETWEEN THE VIGIFLAP AND THE COLLECTOR. PLEASE SEE THE POSSIBLE ORIENTATIONS SHOWN ABOVE.

### THE VIGIFLAP MAY BE INSTALLED INDOORS CONSIDERING THE FOLLOWING:

NFPA 69-2019 (A.12.2.3.4.6) STATES: The minimum design pressure for the ductwork is typically 2 x  $P_{red}$  because the pressure wave reflects off the closed valve. Depending on the distance between the flap valve and the enclosure, pressure piling could further increase the expected peak pressure.

\*\* See Minimum/Maximum Distance Specifications

# SPECIFICATIONS FOR SIZES 4”-32”

## ATEX 16447 Certification Specifications

SIZE	MAX VELOCITY (DIRTY)	MAX VELOCITY (CLEAN)	MIN VESSEL SIZE	MIN DISTANCE (FLOAT)	MIN DISTANCE (LOCKED)	MAX DISTANCE
4”*	8858 FPM	5905 FPM	0.7m <sup>3</sup>	16.4’	19.7’	55.8’ (17m)
5”*	8858 FPM	5905 FPM	0.7m <sup>3</sup>	16.4’	19.7’	55.8’ (17m)
6”	8858 FPM	5905 FPM	0.7m <sup>3</sup>	13.1’	19.7’	55.8’ (17m)
6”	8858 FPM	5905 FPM	1.35m <sup>3</sup>	9.84’	16.4’	55.8’ (17m)
7”	8858 FPM	5905 FPM	0.7m <sup>3</sup>	13.1’	19.7’	55.8’ (17m)
7”	8858 FPM	5905 FPM	1.35m <sup>3</sup>	9.84’	16.4’	55.8’ (17m)
8”	8858 FPM	5905 FPM	1.35m <sup>3</sup>	15.1’	21.6’	55.8’ (17m)
10”	8858 FPM	5905 FPM	1.35m <sup>3</sup>	13.1’	19.7’	55.8’ (17m)
12”	8858 FPM	5905 FPM	2.90m <sup>3</sup>	15.1’	21.6’	55.8’ (17m)
14”	8858 FPM	5905 FPM	2.90m <sup>3</sup>	13.8’	20.3’	55.8’ (17m)
16”	8858 FPM	5905 FPM	4.50m <sup>3</sup>	17.1’	23.6’	55.8’ (17m)
18”	8858 FPM	5905 FPM	4.50m <sup>3</sup>	15.4’	22.0’	55.8’ (17m)
20”	8858 FPM	5905 FPM	6.05m <sup>3</sup>	19.0’	25.6’	55.8’ (17m)
22”	8858 FPM	5905 FPM	6.05m <sup>3</sup>	18.0’	24.6’	55.8’ (17m)
24”	8858 FPM	5905 FPM	7.65m <sup>3</sup>	23.6’	30.2’	55.8’ (17m)
26”	8858 FPM	5905 FPM	7.65m <sup>3</sup>	22.0’	28.5’	55.8’ (17m)
28”	8858 FPM	5905 FPM	7.65m <sup>3</sup>	21.0’	27.5’	55.8’ (17m)
30”	8858 FPM	5905 FPM	10.00m <sup>3</sup>	24.0’	30.5’	55.8’ (17m)
32”	8858 FPM	5905 FPM	10.00m <sup>3</sup>	22.6’	29.2’	55.8’ (17m)

If there is an elbow between the isolated vessel and the VIGIFLAP, use the “Min Distance (Locked)” distance rather than the Float distance, even if the flap is Floating

\*4 and 5 inch Vigiflap can ONLY be installed horizontally

THERE ARE 4 POSSIBLE CASES WHEN INSTALLING THE ATEX CERTIFIED VIGIFLAP:

CASE 1: HORIZONTAL INSTALLATION WITH FLAP IN FLOATING POSITION, NO ELBOWS

CASE 2: HORIZONTAL INSTALLATION WITH FLAP IN LOCKED OPEN POSITION, NO ELBOWS

CASE 3: HORIZONTAL INSTALLATION WITH ELBOW(S)

CASE 4: VERTICAL OR ANGLED INSTALLATION

PLEASE REFER TO THE FOLLOWING PAGES FOR DETAILS FOR EACH CASE.



6729 Guada Coma Dr.  
Schertz, TX 78154  
M: 210-664-4200  
F: 210-664-4220  
info@bossproductamerica.com

VF NA SUP. MANUAL 2023 - FIRST EDITION - VERSION 0010  
RELEASE DATE: 12/2023

## SPECIFICATIONS FOR SIZES 34”-54”

SIZE	MIN VELOCITY	MAX VELOCITY	MIN DISTANCE (FLOAT)	MIN DISTANCE (LOCKED)	MAX DISTANCE
34”	3000 FPM	6000 FPM	23.6ft	30.2ft	55.8ft
36”	3000 FPM	6000 FPM	24.6ft	31.2ft	82ft
38”	3000 FPM	6000 FPM	25.6ft	32.2ft	82ft
40”	3000 FPM	6000 FPM	26.2ft	32.8ft	82ft
42”	3000 FPM	6000 FPM	26.9ft	33.5ft	82ft
44”	3000 FPM	6000 FPM	27.6ft	34.1ft	82ft
46”	3000 FPM	6000 FPM	28.2ft	34.8ft	82ft
48”	3000 FPM	6000 FPM	28.9ft	35.4ft	82ft
50”	3000 FPM	6000 FPM	29.2ft	35.8ft	82ft
52”	3000 FPM	6000 FPM	29.5ft	36.1ft	82ft
54”	3000 FPM	6000 FPM	30.2ft	36.7ft	82ft

\* If there is an elbow between the isolated vessel and the VIGIFLAP, use the “Min Distance (Locked)” distance rather than the Float distance, even if the flap is Floating

THERE ARE 3 POSSIBLE CASES WHEN INSTALLING THE VIGIFLAP:

### UNLIKE THE 6”-32” VIGIFLAP, 4”-5” AND 34”-54” CAN NOT BE INSTALLED VERTICALLY

CASE 1: HORIZONTAL INSTALLATION WITH FLAP IN FLOATING POSITION, NO ELBOWS

CASE 2: HORIZONTAL INSTALLATION WITH FLAP IN LOCKED OPEN POSITION, NO ELBOWS

CASE 3: HORIZONTAL INSTALLATION WITH ELBOW(S)

PLEASE REFER TO THE FOLLOWING PAGES FOR DETAILS FOR EACH CASE.

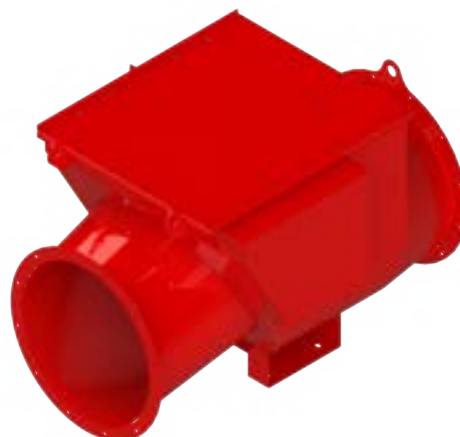

## FLOATING VS LOCKED OPEN POSITIONS

### FLOATING

When the flap is in Floating Position, the flap can freely move up and down with air pressure. The force of the air traveling through the duct keeps the flap open. The benefit of Floating Position is that it can close faster which allows it to be installed at a shorter distance from the explosion risk if installed within parameters of Case 1 on page 9 (see the tables on the previous pages for minimum distance information).

### LOCKED OPEN

When the flap is in Locked Open Position, the flap is mechanically locked in place by springs which keeps it open regardless of air flow or gravity. In the case of an explosion, the force of the blast wave overcomes the force of the springs and the flap closes. Because the flap is held open, the Vigiflap is able to be installed in any orientation and on either the clean or dirty air side of the dust collector.

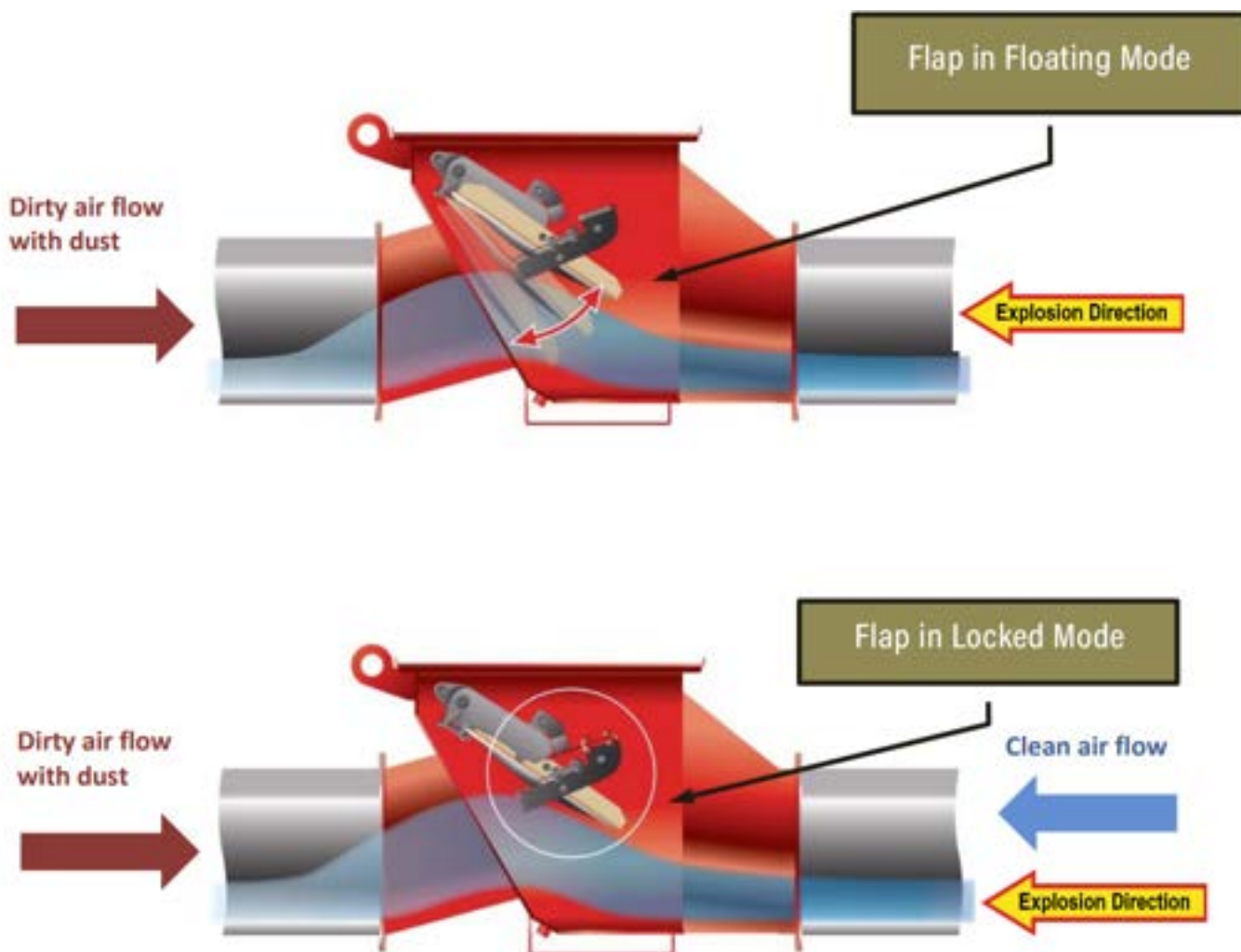

## POSSIBLE CONFIGURATIONS

### CASE 1: HORIZONTAL INSTALLATION WITH FLAP IN FLOATING POSITION, NO ELBOWS

If Vigiflap installed horizontally ( $< \pm 10^\circ$  inclination) with flap in Floating position and no elbows between dust collector and valve: Use Minimum Distances (Floating) from table above, Maximum Distance is 55.8' (17m) for all sizes.

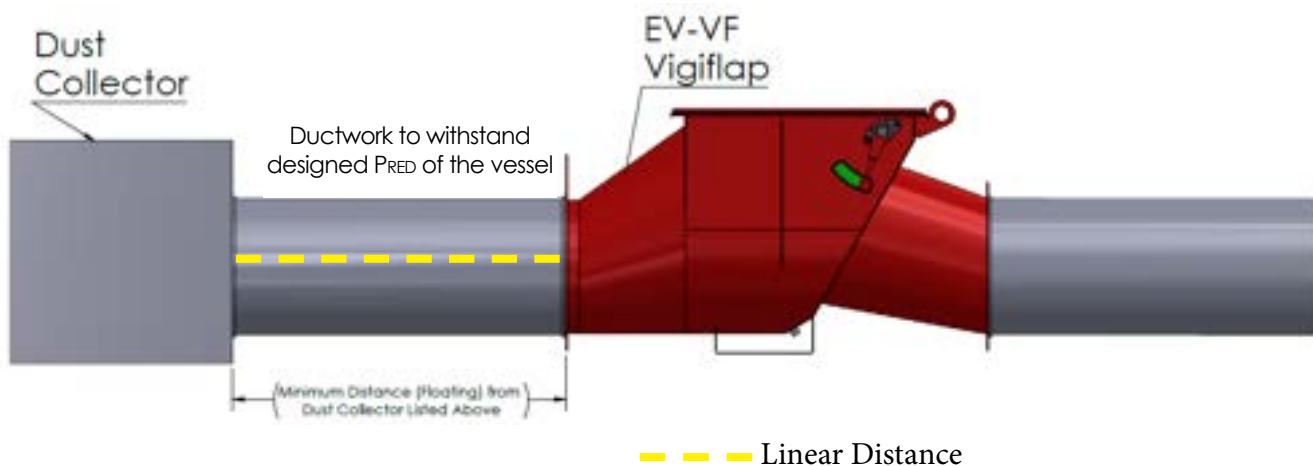

### CASE 2: HORIZONTAL INSTALLATION WITH FLAP IN LOCKED OPEN POSITION, NO ELBOWS

If Vigiflap installed horizontally ( $< \pm 10^\circ$  inclination) with flap in Locked Open position (not Floating) **and no elbows** between dust collector and valve: Use Minimum Distances (Locked Open) from table above, Maximum Distance is 55.8' (17m) for all sizes.

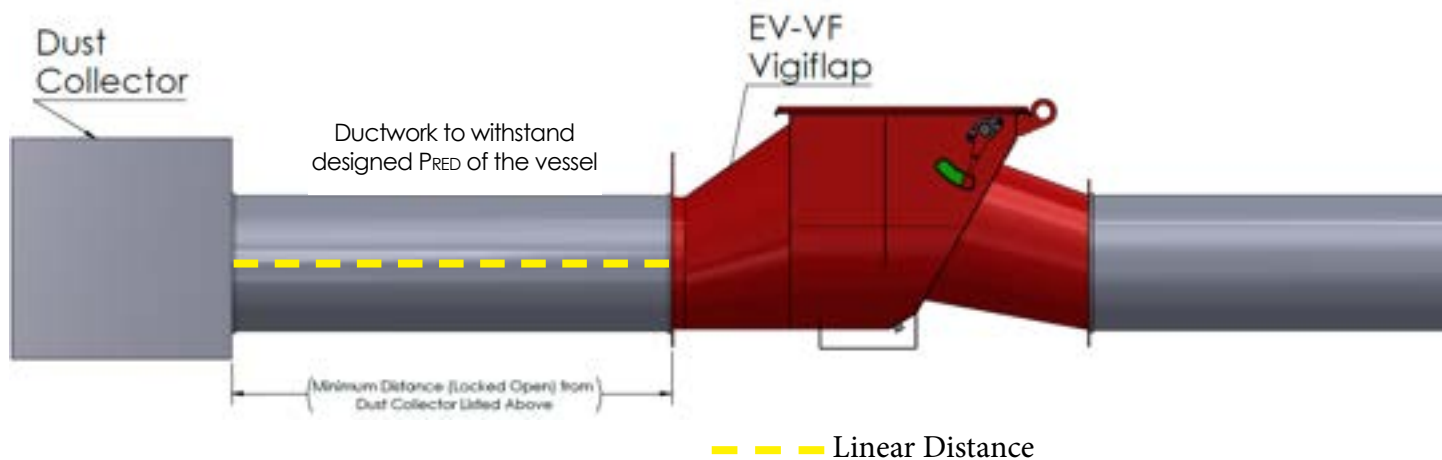

### CASE 3: HORIZONTAL INSTALLATION WITH ELBOW(S) 4-32" ONLY

If Vigiflap installed horizontally ( $< \pm 10^\circ$  inclination) **with** elbow(s) between dust collector and valve, flap can be either in Floating or Locked Open position: Use Minimum Distances (Locked Open) from table above regardless of flap position. Maximum Distance is 55.8' (17m) for all sizes. **NOTE:** Min. and Max. Distances are Linear Distances.

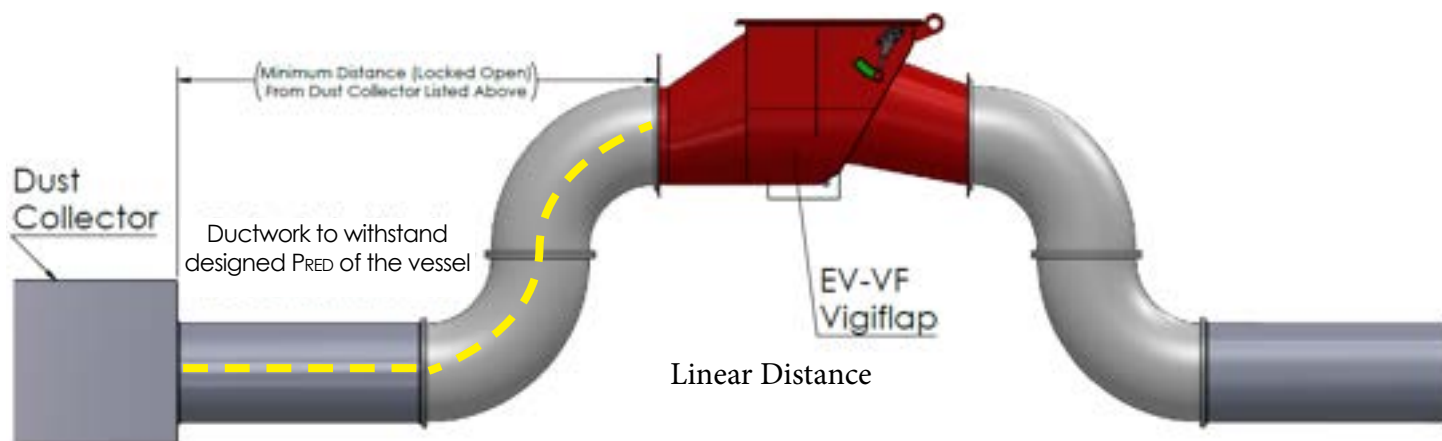

### CASE 4: VERTICAL OR ANGLED INSTALLATION (ONLY FOR VIGIFLAP SIZES 6" -32")

If Vigiflap installed vertically or in angled position ( $> \pm 10^\circ$  inclination) with unlimited amount of elbows, flap is **recommended** to be in Locked Open position (not Floating): Use Minimum Distances (Locked Open) from table above, Maximum Distance is 55.8' (17m) for all sizes. **NOTE:** Vertical Distance must be at least 5x Vigiflap  $\varnothing$  from any elbow. **NOTE:** Min. and Max. Distances are Linear Distances.

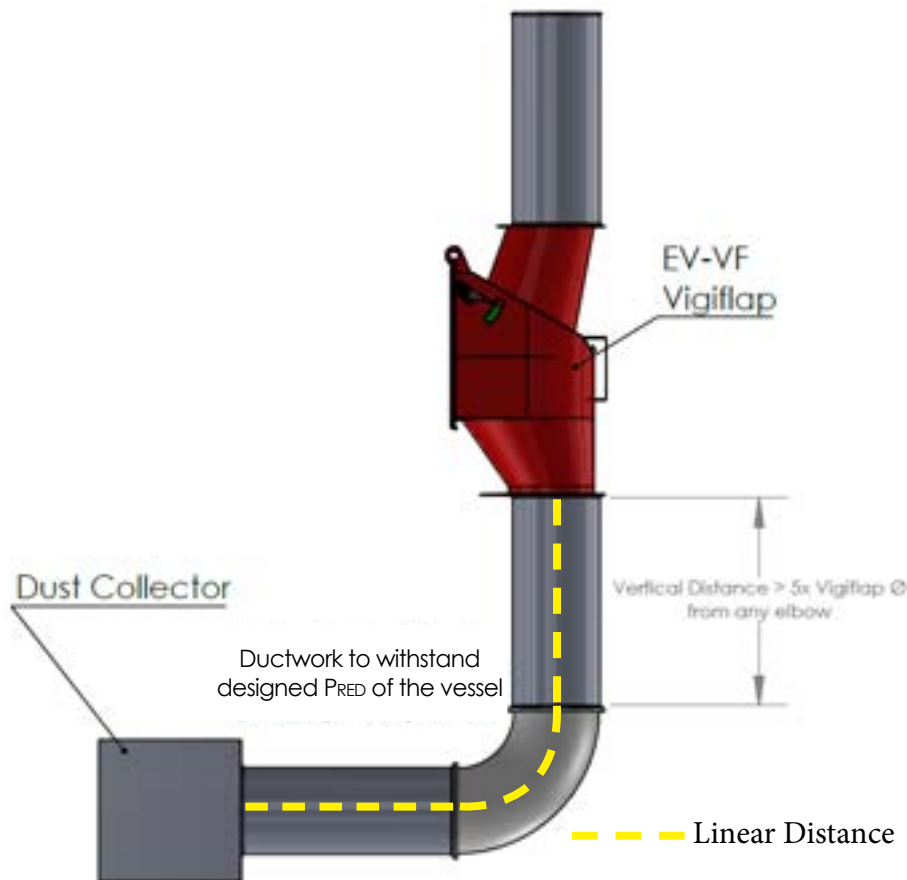

ALLOWED ORIENTATIONS OF THE 6-32" VIGIFLAP (4",5", AND 34-54" CAN ONLY BE INSTALLED HORIZONTALLY):

- POSITIONS A AND B REFER TO HORIZONTAL INSTALLATION - CASE 1,2, AND 3 ( $< \pm 10^\circ$  INCLINATION)
  - ▶ IF IN THE WHITE ZONE, FLAP CAN BE EITHER IN FLOATING OR LOCKED OPEN POSITION RESPECTING MIN. AND MAX. DISTANCES FROM TABLE ABOVE
- POSITIONS C, D, E, F, G, AND H REFER TO VERTICAL OR ANGLED INSTALLATION - CASE 4 ( $> \pm 10^\circ$  INCLINATION)
  - ▶ IF IN THE GREEN ZONE, FLAP CAN BE EITHER IN FLOATING OR LOCKED OPEN POSITION
  - ▶ IF IN THE BLUE ZONE, FLAP IS RECOMMENDED TO BE IN LOCKED OPEN POSITION TO AVOID HIGH PRESSURE DROP ACROSS THE VALVE

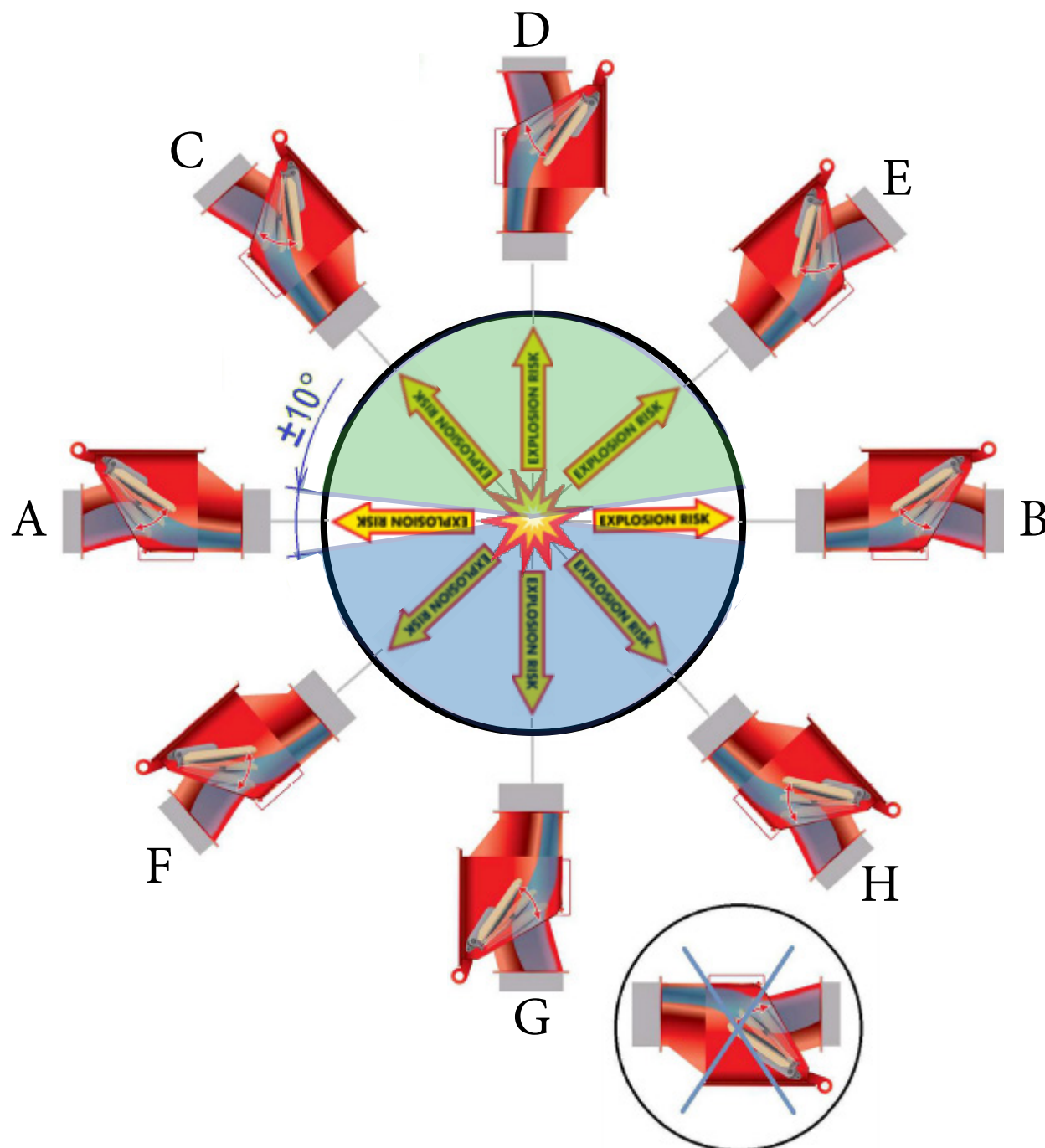

THERE IS A  $\pm 10^\circ$  INSTALLATION TOLERANCE SHOWN IN PICTURE BELOW:

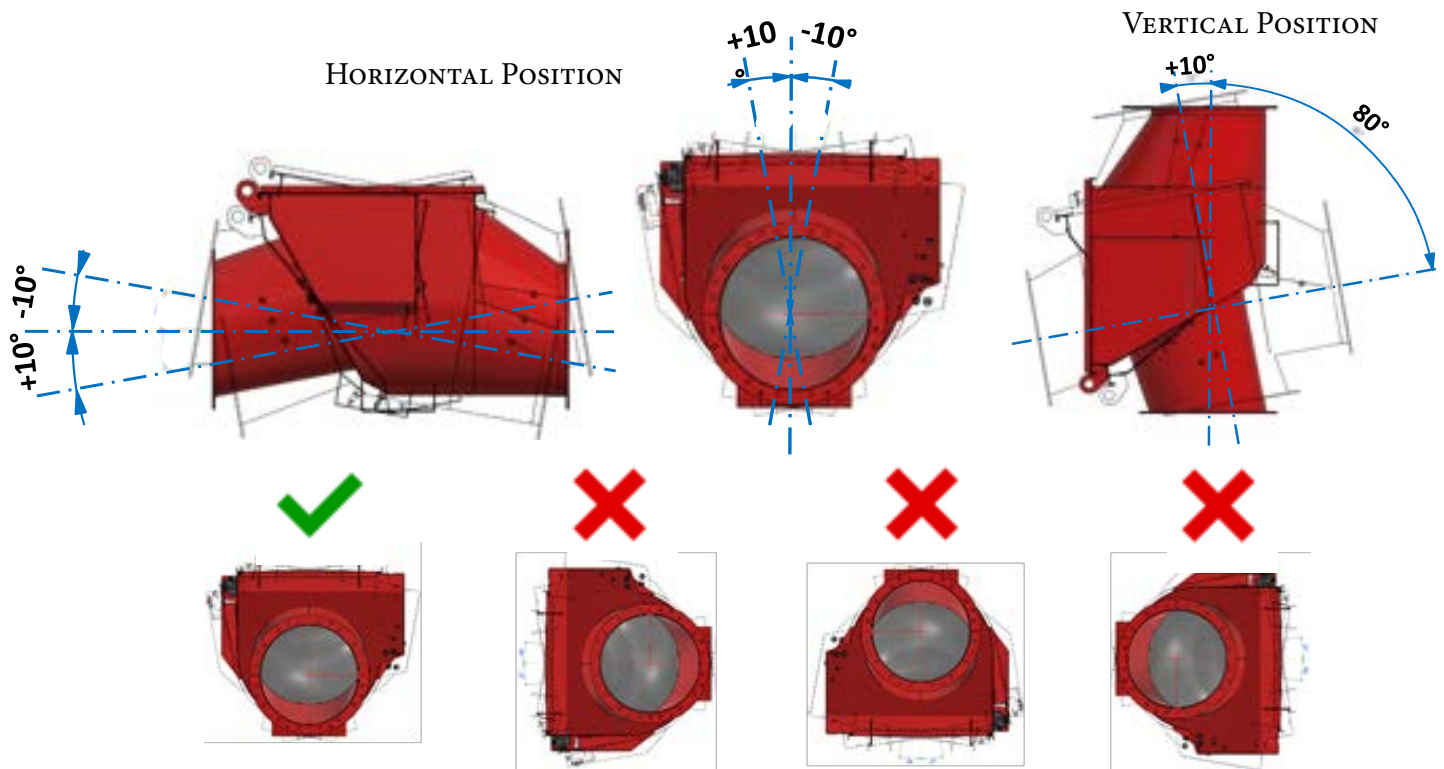

IF VIGIFLAP IS INSTALLED ON THE DIRTY AIR SIDE, FLAP CAN BE EITHER IN THE LOCKED OPEN OR FLOATING POSITION. FOLLOW CASES 1,2,3, AND 4 REQUIREMENTS ACCORDINGLY.

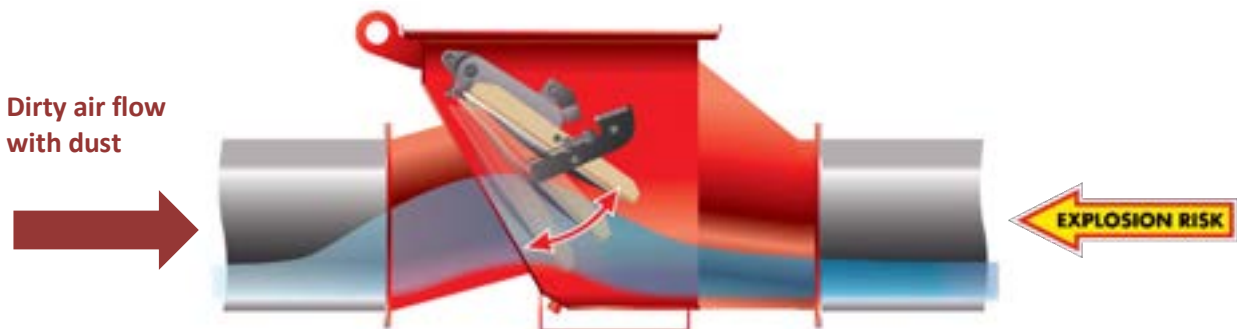

IF VIGIFLAP IS INSTALLED ON THE CLEAN AIR SIDE, FLAP **MUST** BE IN THE LOCKED OPEN POSITION. FOLLOW CASES 2,3, AND 4 REQUIREMENTS ACCORDINGLY.

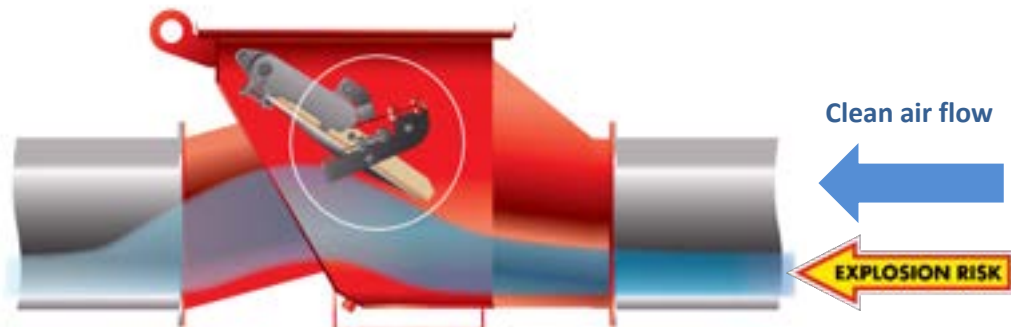

# VIGIFLAP (VF) DIMENSIONS (DUCT Ø 4" TO 32")

**SIZES 4" - 32" RATED FOR:**

Class ST 2 Applications

Kst max 250 bar m/s

Pred max 0.50 bar

Certification EN 16447

\*NOTE: Larger sizes have support fins across the top of the access panel not shown in diagram. Please see individual drawings\*

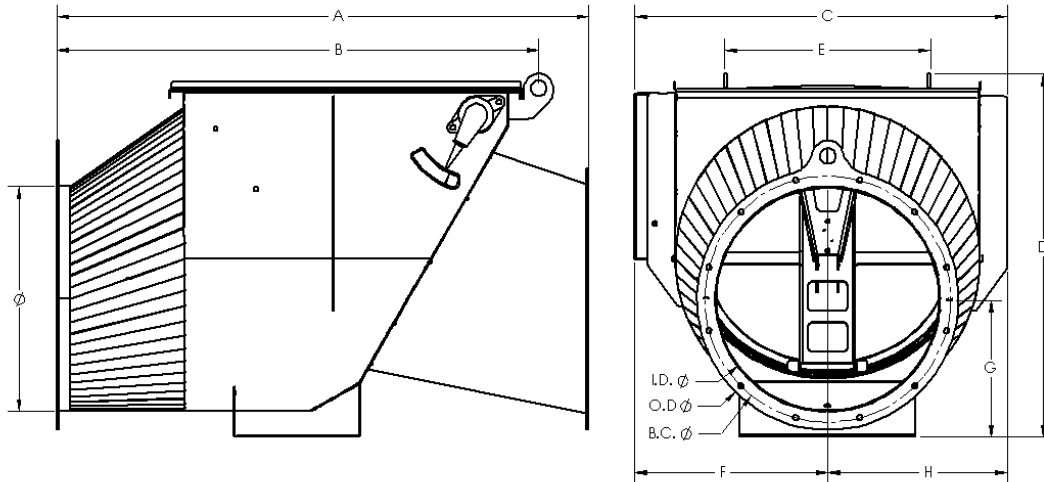

MODEL#	I.D.Ø	A	B	C	D	E	F	G	H	B.C.	O.D.	LBS
VF04	4in	24.5	22.4	14.1	13.7	6.1	7.6	4.0	6.5	5.3	6.1	35
VF05	5in	22.8	21.0	14.1	13.7	6.1	7.6	4.5	6.5	6.3	6.3	35
VF06	6in	24.8	25.5	15.7	15.2	8.03	8.5	4.7	7.2	7.3	8.1	46
VF07	7in	22.03	22.9	15.7	15.2	8.03	8.5	5.2	7.2	8.5	9.4	40
VF08	8in	33.72	29.9	19.2	18.3	11.6	10.3	5.4	8.9	9.6	10.4	73
VF10	10in	26.4	27.1	19.2	18.3	11.6	10.3	6.4	8.9	11.8	12.8	78
VF12	12in	38.0	33.8	23.2	22.6	15.5	12.3	7.8	10.9	14.0	15.1	98
VF14	14in	30.6	31.0	23.2	22.6	15.5	12.3	8.7	10.9	16.0	17.1	91
VF16	16in	42.8	38.7	28.7	27.8	16.2	14.7	9.8	13.9	18.0	19.1	180
VF18	18in	35.2	35.9	28.7	27.8	16.2	14.7	10.8	13.9	20.0	21.1	170
VF20	20in	47.1	42.7	33.0	32.1	18.2	17.1	12.2	15.9	21.8	23.1	240
VF22	21.8in	38.6	39.6	33.0	32.1	18.2	17.1	13.2	15.9	23.8	25.1	230
VF24	23.8in	60.5	51.6	39.0	40.9	26.1	20.0	14.5	18.9	25.9	27.1	400
VF26	25.8in	53.1	48.8	39.0	40.9	26.1	20.0	15.4	18.9	28.4	30.1	380
VF28	27.8in	44.7	45.9	39.0	40.9	26.1	20.0	16.5	18.9	30.4	32.1	370
VF30	29.7in	68.4	60.0	47.3	47.8	31.5	23.7	17.5	23.6	32.4	34.1	730
VF32	31.7in	60.8	57.1	47.3	47.8	31.5	23.7	18.5	23.6	34.4	36.1	710

# VIGIFLAP (VF) DIMENSIONS (DUCT Ø 34" TO 54")

SIZES 34" to 54" Recommended FOR:

Class ST 2 Applications

Kst max 250 bar m/s

Pred max 0.50 bar

\*NOTE: These sizes have support fins across the top of the access Panel not shown in diagram. Please see individual drawings\*

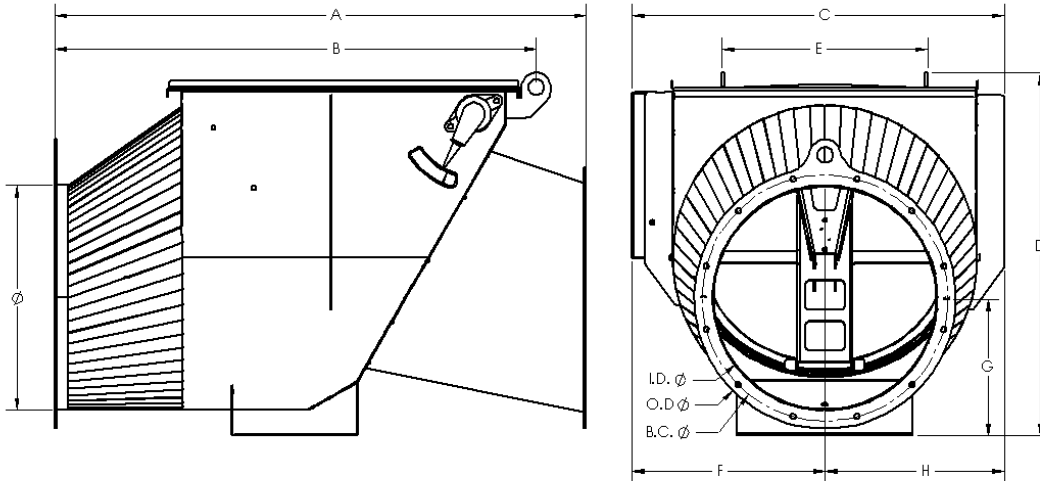

MODEL#	I.D.Ø	A	B	C	D	E	F	G	H	B.C.	O.D.	LBS
VF34	34in	53.1	55.9	47.2	47.8	31.2	23.7	19.3	23.5	36.4	38.1	675
VF36	36in	74.1	75.0	53.6	55.2	37.1	27.1	21.4	26.5	38.4	40.1	968
VF38	38in	65.3	67.3	53.6	55.2	37.1	27.1	22.4	26.5	40.4	42.1	933
VF40	40in	58.0	61.7	53.6	55.2	49.4	27.1	23.4	26.5	42.4	44.1	891
VF42	42in	57.6	60.6	53.6	55.2	37.1	27.1	23.2	26.5	44.4	46.1	899
VF44	44in	97.9	98.8	66.7	68.5	49.4	33.2	25.2	33.5	46.4	48.1	1748
VF46	46in	90.7	92.3	66.7	68.5	49.0	33.2	26.2	33.5	48.4	50.1	1687
VF48	48in	83.3	85.9	66.7	68.5	49.4	33.2	27.5	33.5	50.4	52.1	1627
VF50	50in	77.5	79.3	66.7	68.5	49.4	33.2	28.3	33.5	52.4	54.1	1576
VF52	52in	71.4	75.2	66.7	68.5	49.4	33.2	29.3	33.5	54.4	56.1	1539
VF54	54in	70.1	73.5	66.7	68.5	49.4	33.2	29.3	33.5	56.4	58.1	1526

# VIGIFLAP (VF) PRESSURE DROP 4"-5" LOCKED OPEN POSITION DIRTY AIR SIDE

Ø100mm - Ø125mm  
Ø4" - Ø5"

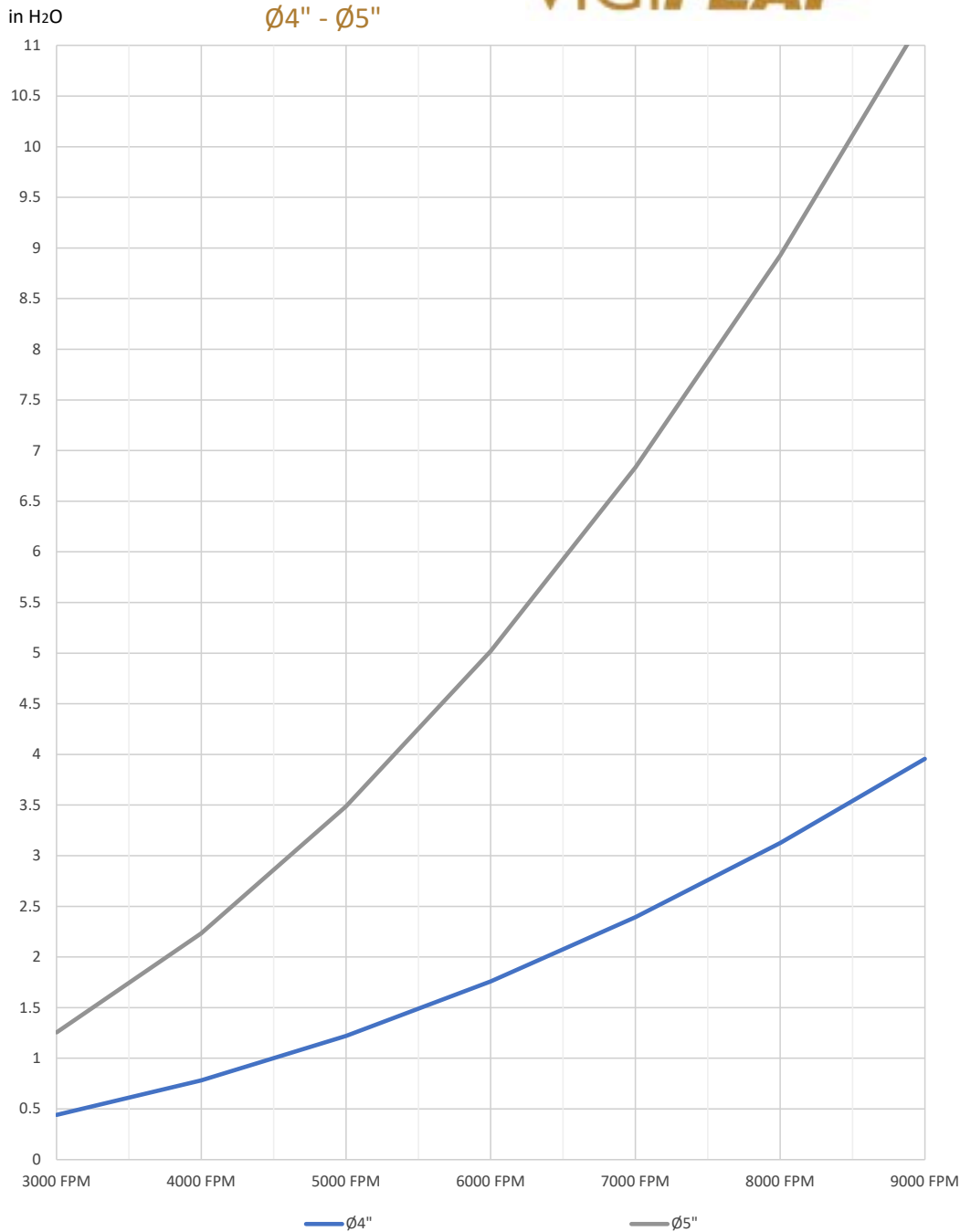

PRESSURE DROP IN INH <sub>2</sub> O							
DIAMETER (IN)	3000 FPM	4000 FPM	5000 FPM	6000 FPM	7000 FPM	8000 FPM	9000 FPM
Ø4	0.44	0.78	1.22	1.76	2.39	3.13	3.96
Ø5	1.26	2.23	3.49	5.02	6.83	8.93	11.30



6729 Guada Coma Dr.  
Schertz, TX 78154  
M: 210-664-4200  
F: 210-664-4220  
info@bossproductamerica.com

# VIGIFLAP (VF) PRESSURE DROP LOCKED OPEN POSITION DIRTY AIR SIDE

**VIGIFLAP®**

Ø160mm - Ø800mm  
Ø6" - Ø32"

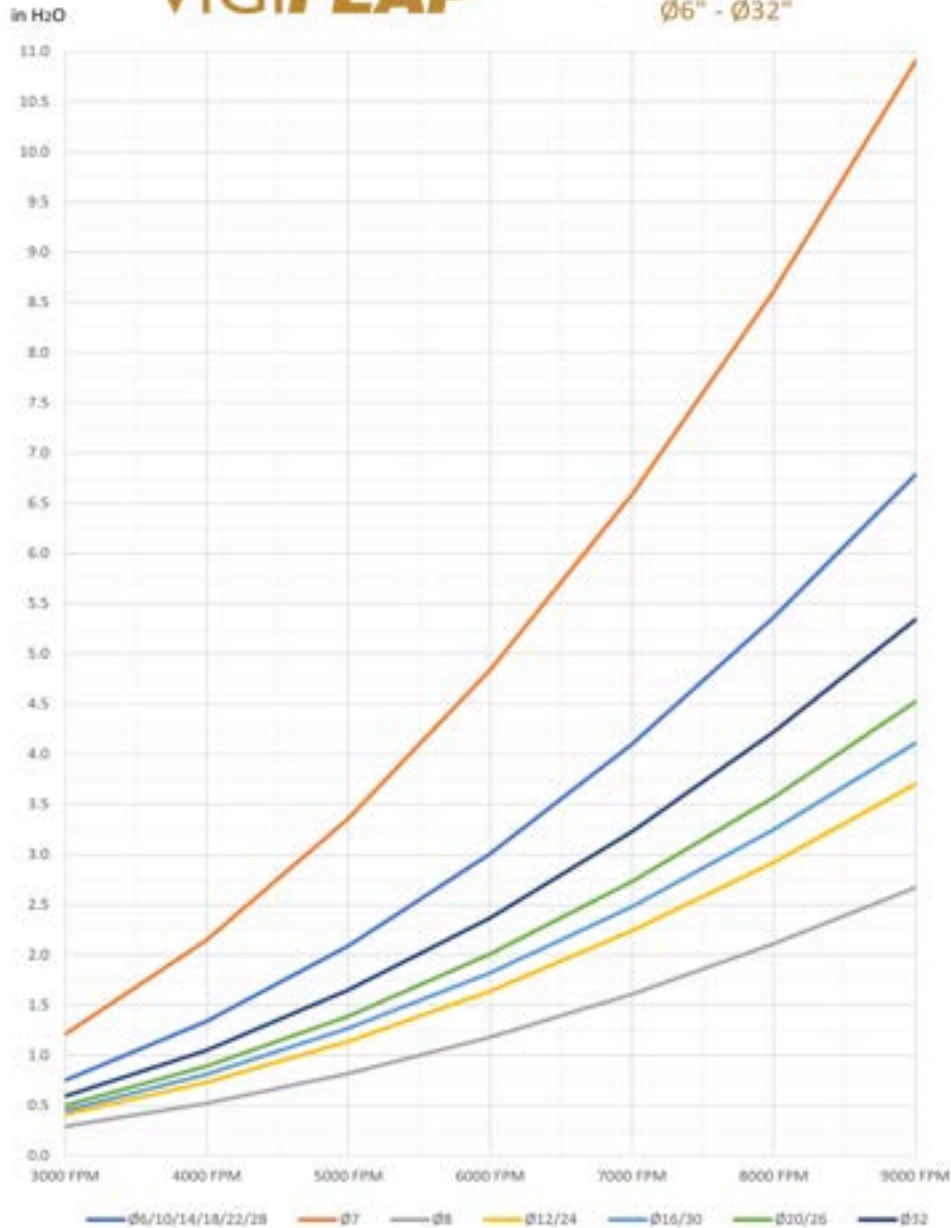

PRESSURE DROP IN INH <sub>2</sub> O						
DIAMETER (IN)	3000 FPM	4000 FPM	5000 FPM	6000 FPM	7000 FPM	8000 FPM
Ø6/10/14/18/22/28	0.75	1.34	2.09	3.01	4.10	5.36
Ø7	1.21	2.15	3.36	4.84	6.59	8.61
Ø8	0.29	0.52	0.82	1.18	1.61	2.11
Ø12/24	0.41	0.73	1.14	1.64	2.24	2.92
Ø16/30	0.45	0.81	1.27	1.82	2.48	3.25
Ø20/26	0.50	0.89	1.39	2.01	2.73	3.57
Ø32	0.59	1.05	1.65	2.37	33.2	4.22



6729 Guada Coma Dr.  
Schertz, TX 78154  
M: 210-664-4200  
F: 210-664-4220  
info@bossproductamerica.com

# LARGE SIZED VIGIFLAP (VF) PRESSURE DROP LOCKED OPEN POSITION DIRTY AIR SIDE

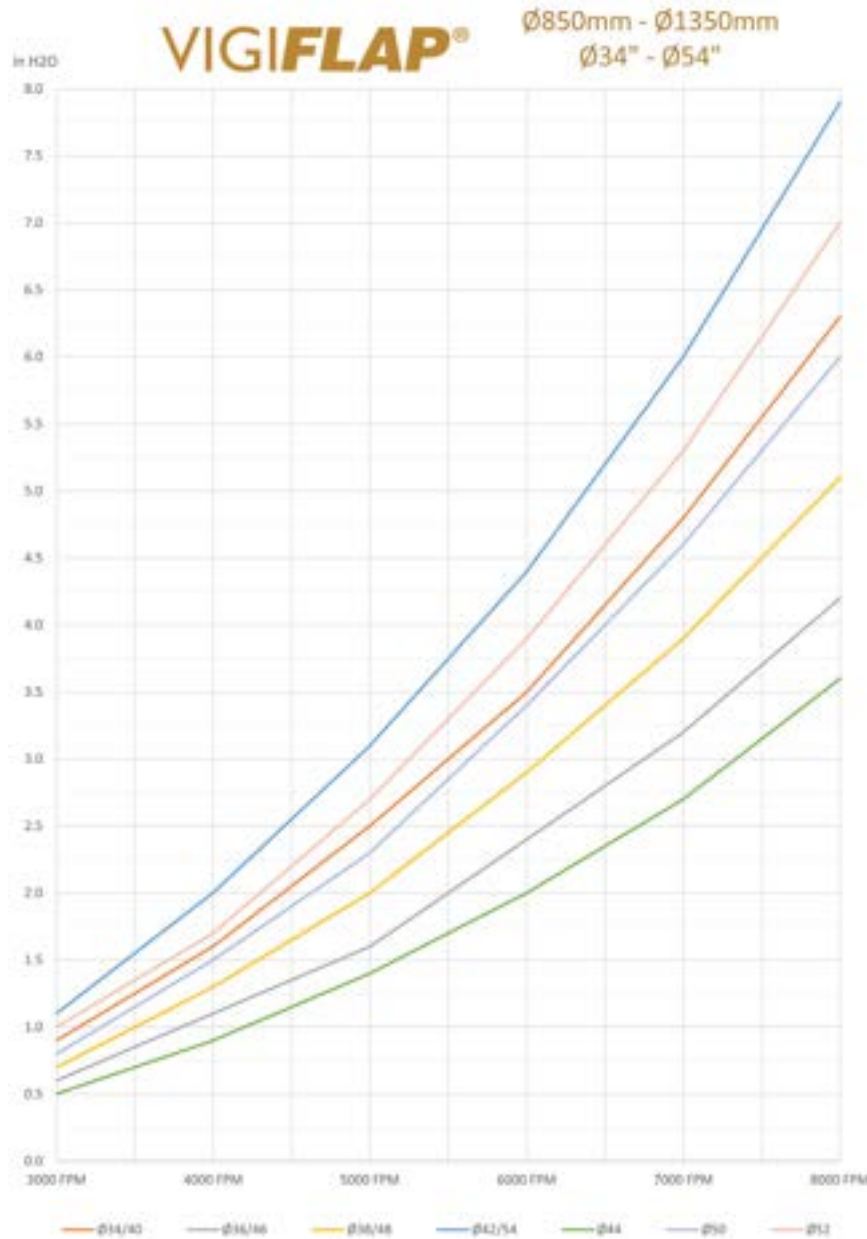

PRESSURE DROP IN INH <sub>2</sub> O						
DIAMETER (IN)	3000 FPM	4000 FPM	5000 FPM	6000 FPM	7000 FPM	8000 FPM
Ø34/40	0.90	1.60	2.50	3.50	4.80	6.30
Ø36/46	0.60	1.10	1.60	2.40	3.20	4.20
Ø38/48	0.70	1.30	2.00	2.90	3.90	5.10
Ø42/54	1.10	2.00	3.10	4.40	6.00	7.90
Ø44	0.50	0.90	1.40	2.00	2.70	3.60
Ø50	0.80	1.50	2.30	3.40	4.60	6.00
Ø52	1.00	1.70	2.70	3.90	5.30	7.00



6729 Guada Coma Dr.  
Schertz, TX 78154  
M: 210-664-4200  
F: 210-664-4220  
info@bossproductamerica.com

# VIGIFLAP (VF) PRESSURE DROP 4"-5" FLOATING POSITION DIRTY AIR SIDE

Ø100mm - Ø125mm  
Ø4" - Ø5"

**VIGIFLAP®**

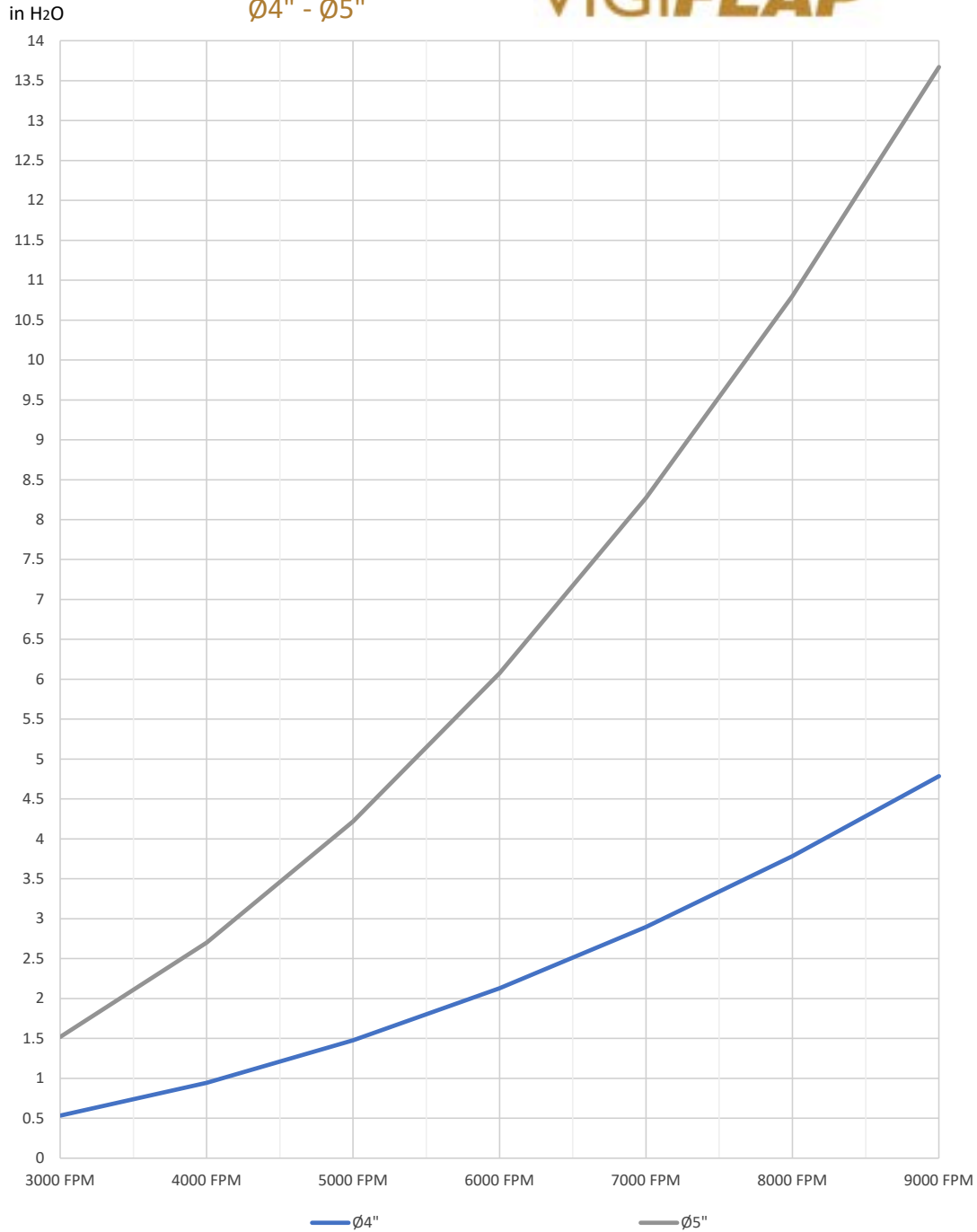

PRESSURE DROP IN INH2O							
DIAMETER (IN)	3000 FPM	4000 FPM	5000 FPM	6000 FPM	7000 FPM	8000 FPM	9000 FPM
Ø4	0.53	0.95	1.48	2.13	2.90	3.78	4.79
Ø5	1.52	2.70	4.22	6.08	8.27	8.27	13.67



6729 Guada Coma Dr.  
Schertz, TX 78154  
M: 210-664-4200  
F: 210-664-4220  
info@bossproductamerica.com

# VIGIFLAP (VF) PRESSURE DROP FLOATING POSITION DIRTY AIR SIDE

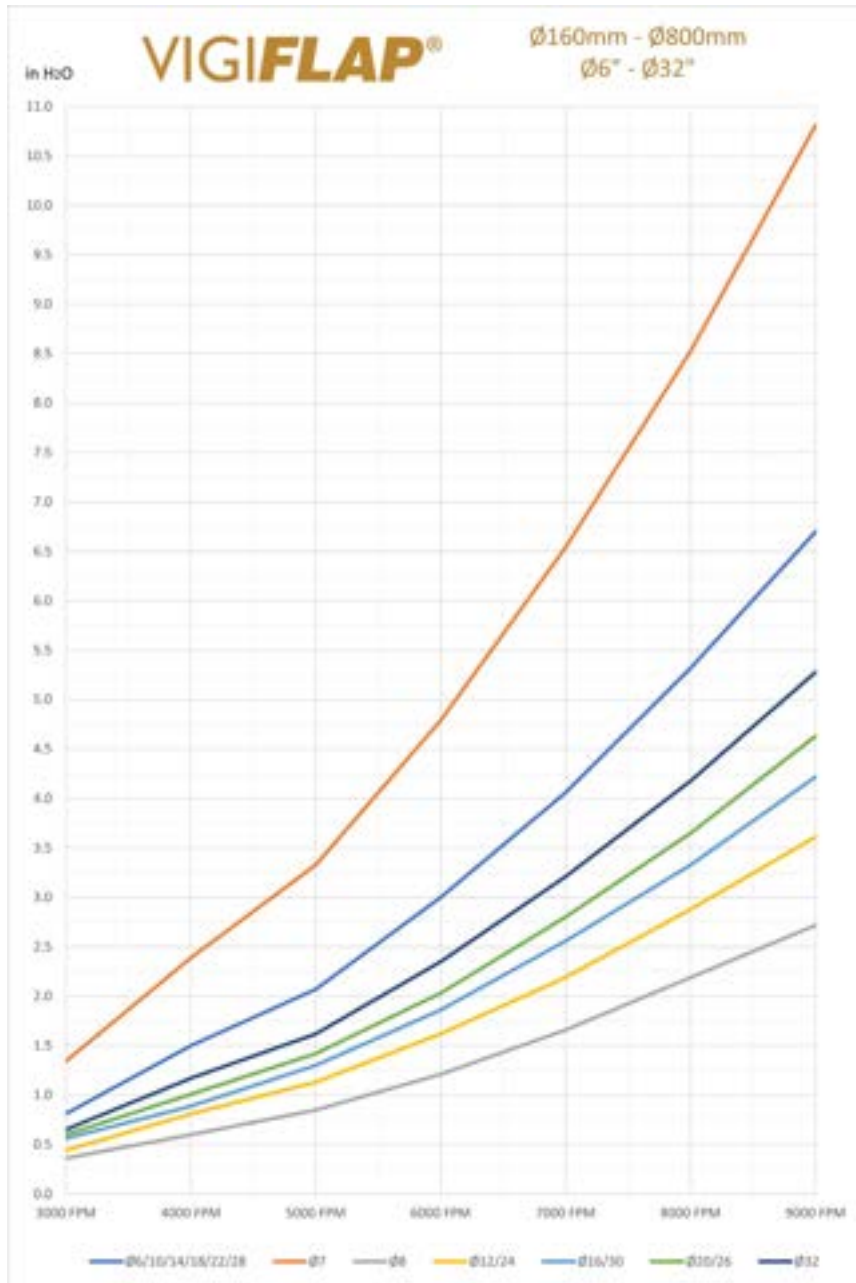

PRESSURE DROP IN INH <sub>2</sub> O						
DIAMETER (IN)	3000 FPM	4000 FPM	5000 FPM	6000 FPM	7000 FPM	8000 FPM
Ø6/10/14/18/22/28	0.81	1.50	2.07	3.00	4.06	5.32
Ø7	1.34	2.39	3.33	4.79	6.54	8.53
Ø8	0.36	0.60	0.85	1.21	1.66	2.19
Ø12/24	0.44	0.81	1.13	1.62	2.19	2.88
Ø16/30	0.56	0.89	1.30	1.86	2.56	3.33
Ø20/26	0.60	1.01	1.42	2.03	2.80	3.65
Ø32	0.65	1.17	1.62	2.35	3.21	4.18



6729 Guada Coma Dr.  
Schertz, TX 78154  
M: 210-664-4200  
F: 210-664-4220  
info@bossproductamerica.com

# VIGIFLAP (VF) PRESSURE DROP 4"-5" LOCKED OPEN POSITION CLEAN AIR SIDE

Ø100mm - Ø125mm  
Ø4" - Ø5"

**VIGIFLAP®**

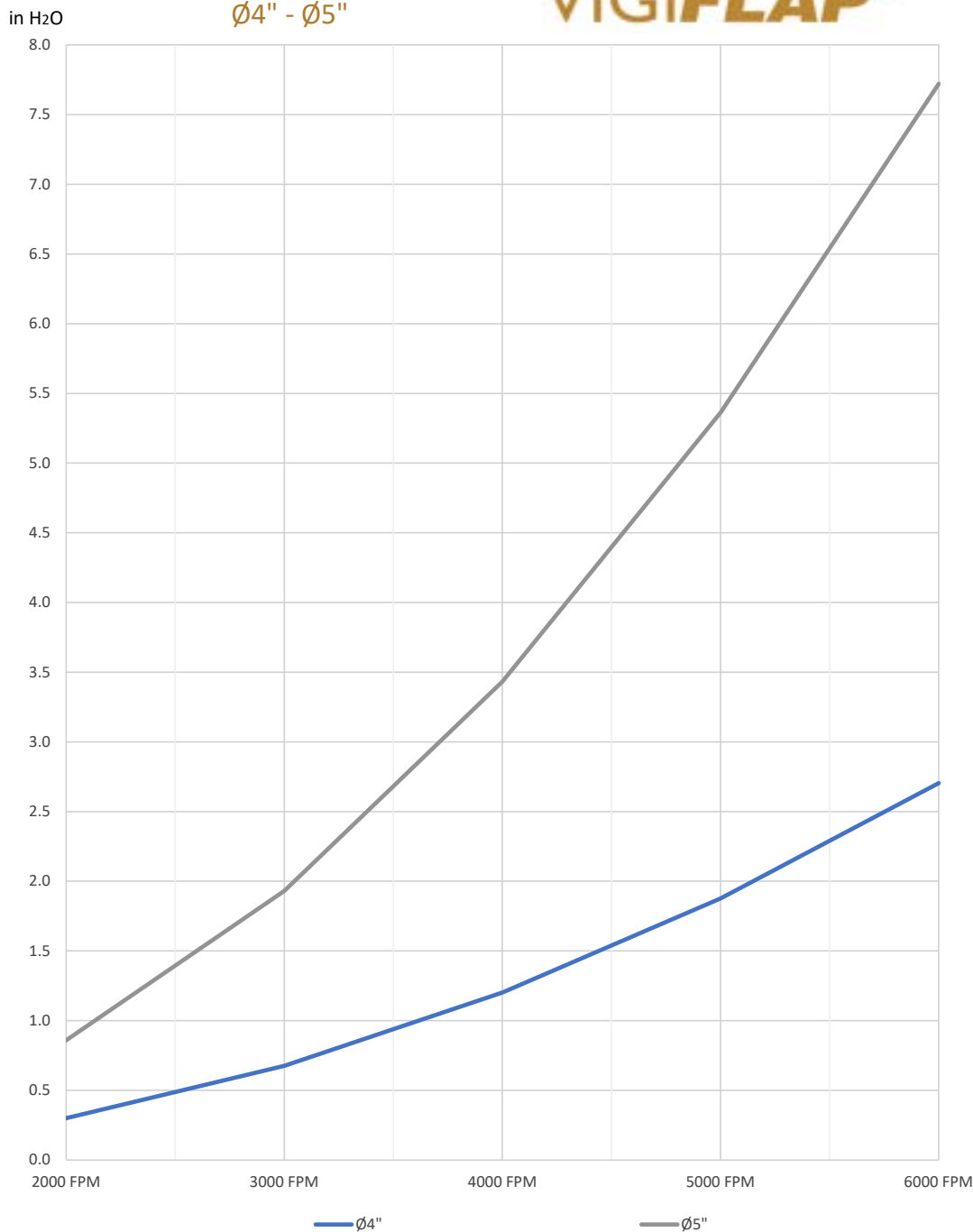

PRESSURE DROP IN INH <sub>2</sub> O				
DIAMETER (IN)	3000 FPM	4000 FPM	5000 FPM	6000 FPM
Ø4	0.30	1.20	1.88	2.70
Ø5	0.86	1.93	5.36	7.72



6729 Guada Coma Dr.  
Schertz, TX 78154  
M: 210-664-4200  
F: 210-664-4220  
info@bossproductamerica.com

# VIGIFLAP (VF) PRESSURE DROP LOCKED OPEN POSITION CLEAN AIR SIDE

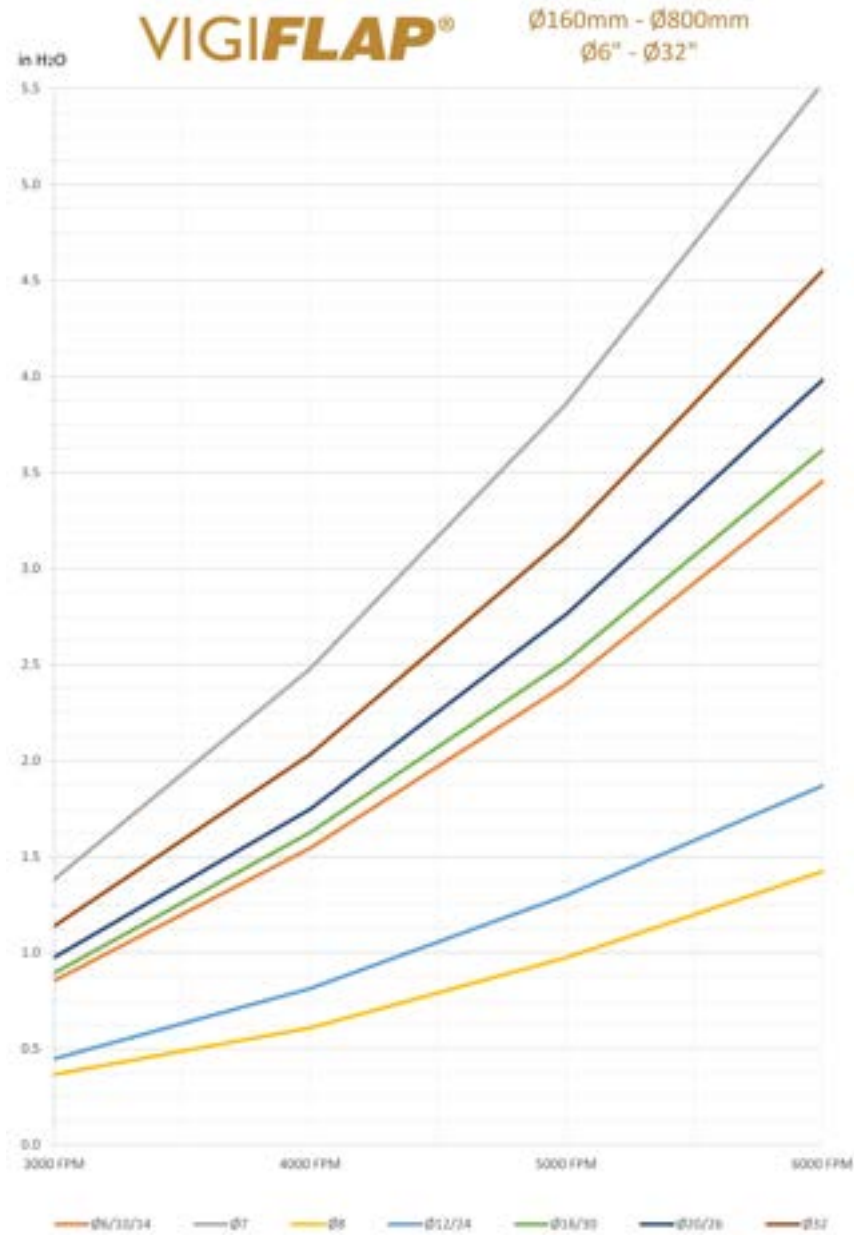

PRESSURE DROP IN INH <sub>2</sub> O				
DIAMETER (IN)	3000 FPM	4000 FPM	5000 FPM	6000 FPM
Ø6/10/14	0.85	1.54	2.40	3.45
Ø7	1.38	2.48	3.86	5.53
Ø8	0.37	0.61	0.98	1.42
Ø12/24	0.45	0.81	1.30	1.87
Ø16/30	0.89	1.63	2.52	3.62
Ø18/22/28	1.46	2.56	4.02	5.81
Ø20/26	0.98	1.75	2.76	3.98
Ø32	1.14	2.03	3.217	4.55



6729 Guada Coma Dr.  
Schertz, TX 78154  
M: 210-664-4200  
F: 210-664-4220  
info@bossproductamerica.com

## VIGILEX VIGIFLAP LOCKING MECHANISM 4"-32"

The Vigiflap is shipped with the flap set in the Locked Position. To use the Vigiflap in Floating Position, use the following instructions:

### FOR FLOATING FLAP POSITION FOR 4" TO 18"

Take off the following parts:

- A) Spring strip
- B) Pin
- C) Bolt
- D) Pin lock
- E) Locked open Leaf spring

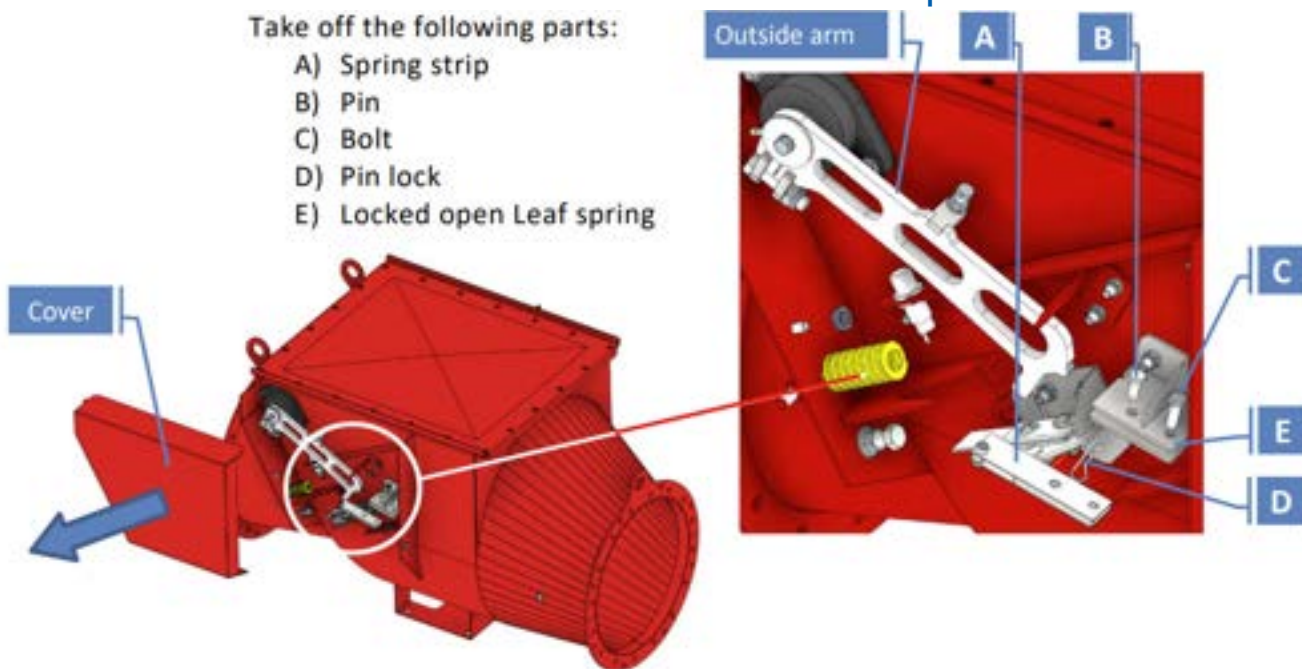

### FOR FLOATING FLAP POSITION FOR 20-32"

#### VIGIFLAP floating flap mode

Take off the following parts:

- A) Spring strip
- B) Pin
- C) Bolt
- D) Pin lock
- E) Kept open spring support

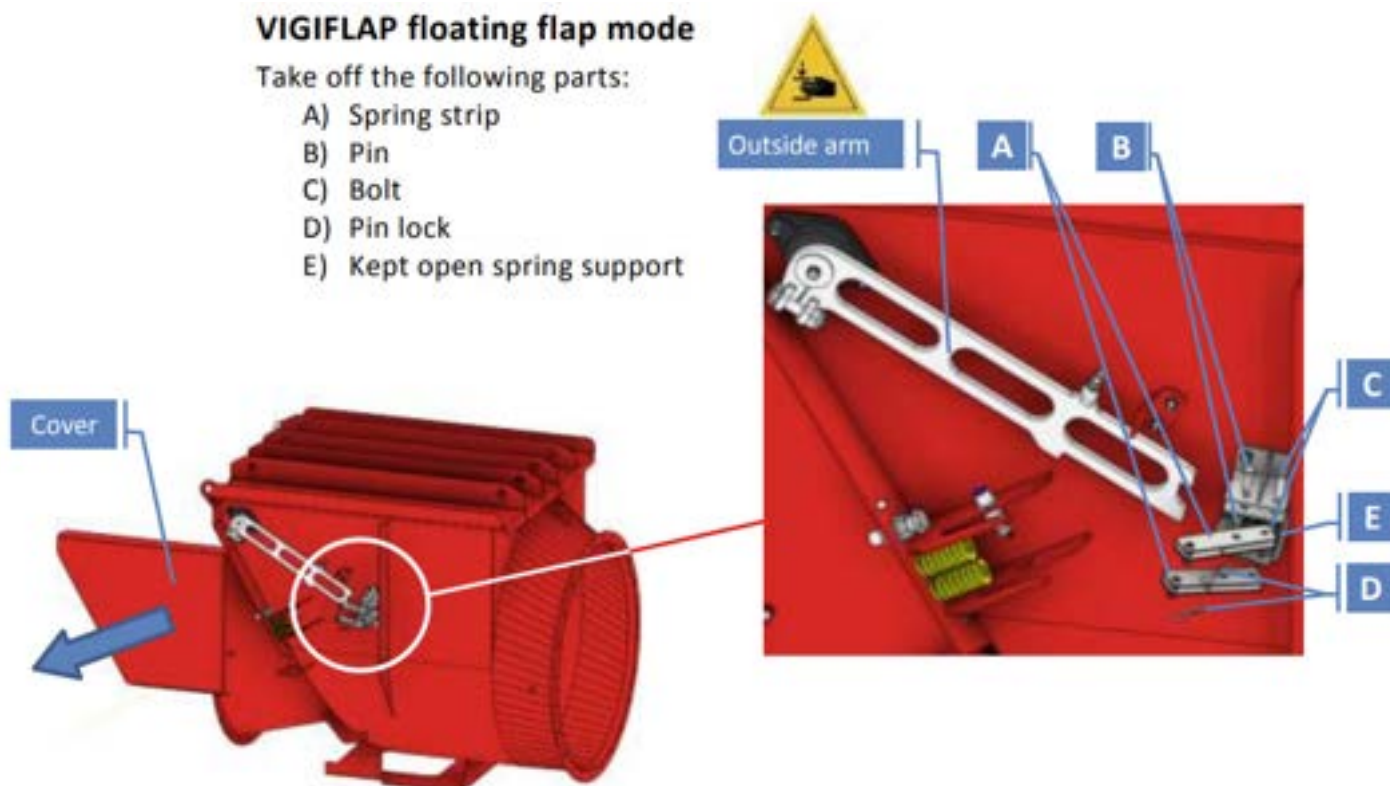

## VIGILEX VIGIFLAP LOCKING MECHANISM

To rearm the Vigiflap in Locked Position, use the following instructions:

Step 1: Turn the Spring Strips (A) outwards and then raise the Outside Arm against the Top Stop (F).  
*The example image below is of the Vigiflap 20" with double spring strips. Operation is the same for sizes 4" through 32", with the only difference being the number of spring strips.*

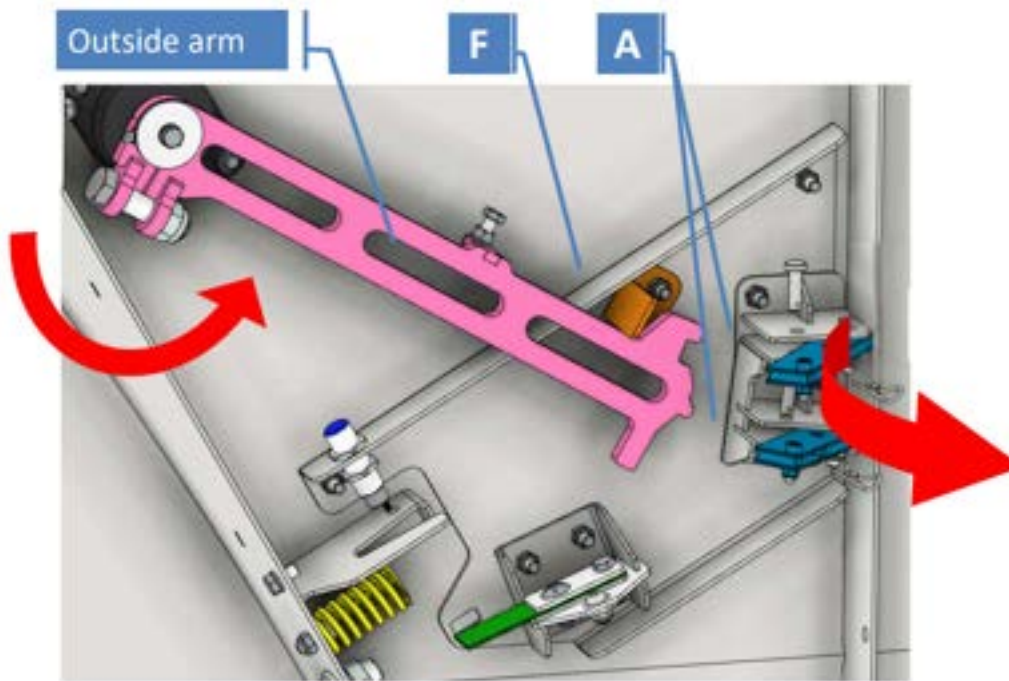

STEP 2: Raise the arm against the top stop and turn the spring strips back against the outside arm (C).  
Insert bolts (B) and lock in position with Cotter Pins (D).

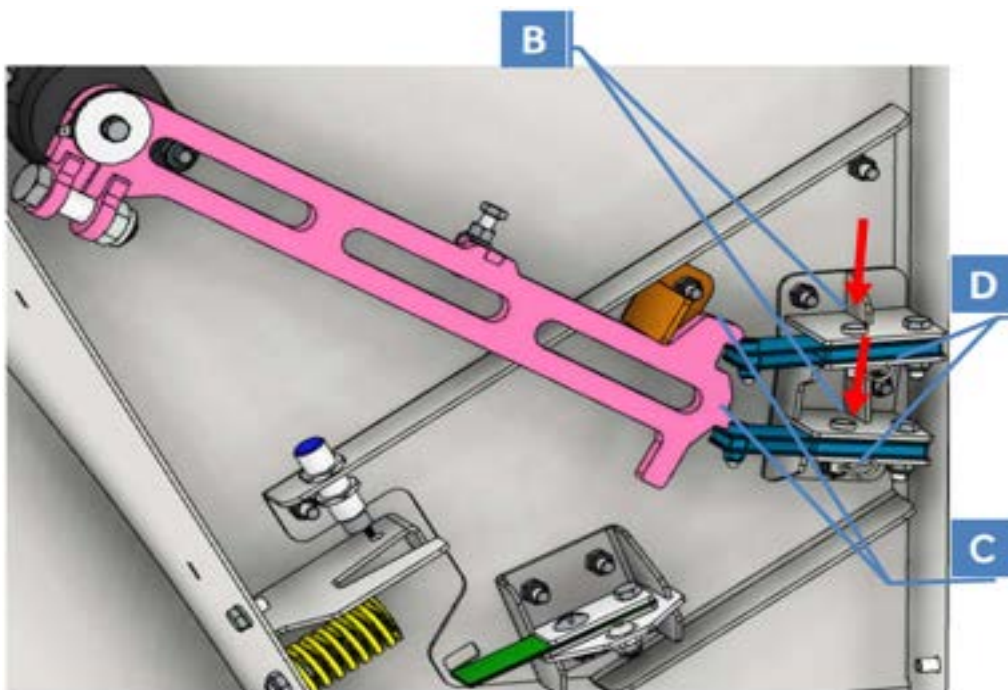

## VIGILEX VIGIFLAP LOCKING MECHANISM FOR > 34”

The Vigiflap comes set in Locked Position. To use the Vigiflap in Floating Position, use the following instructions:

Step 1: Attach the handling system (MS), and use it to raise the arm off the Spring Blades (A) as shown in the image below.

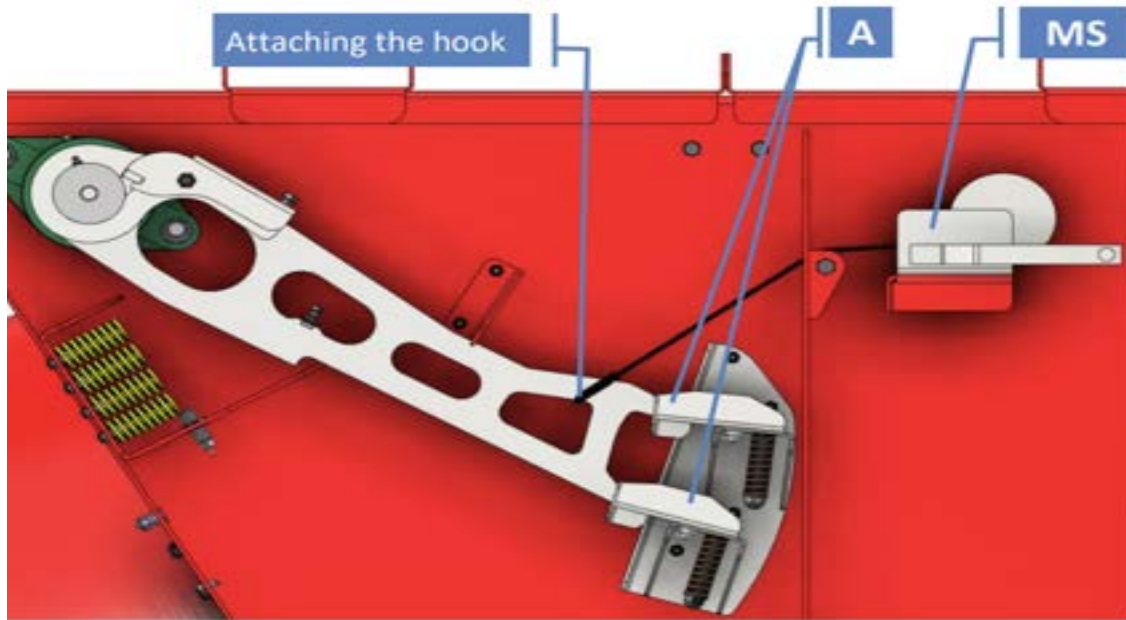

Step 2: Once the outside arm is raised, remove the Spring Blades (A), Pins (B), Bolts (C), Pin Lock (D), and Spring Support (E). Lower the outside arm again and remove the handling system.

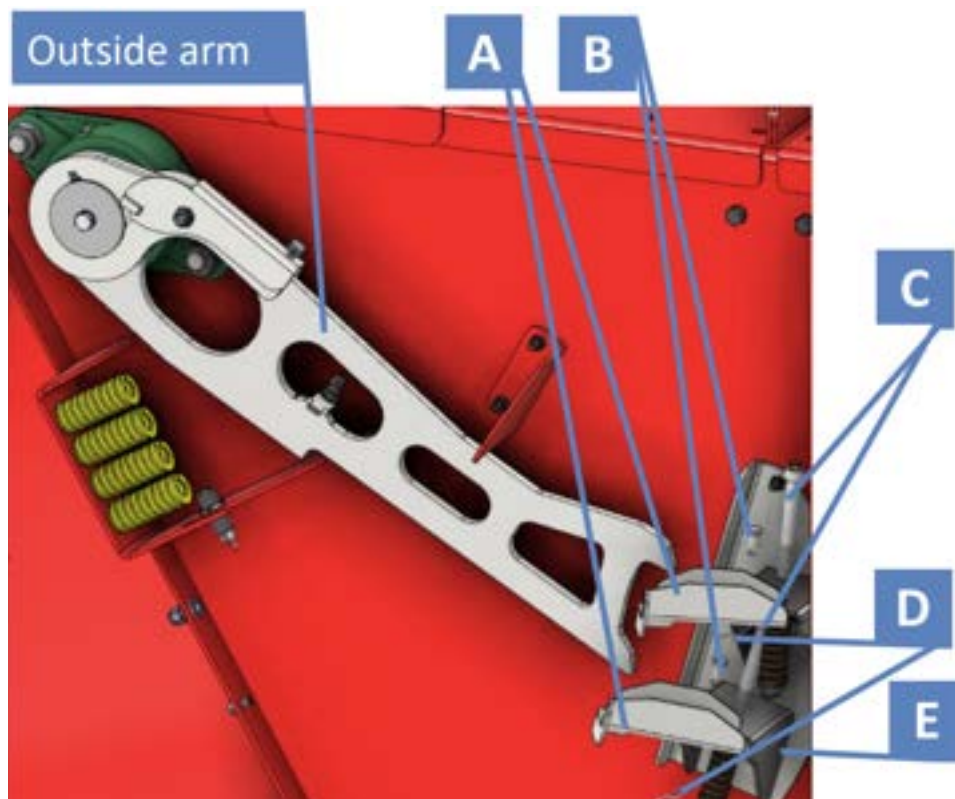

## VIGILEX VIGIFLAP LOCKING MECHANISM FOR >34"

WHEN THE VIGIFLAP TRIGGERS, THE FLAP WILL BE LOCKED IN PLACE WITH A NUMBER OF LATCHES. THESE LATCHES MUST BE RELEASED BEFORE THE VIGIFLAP CAN BE REARMED.

To release the latches, remove the upper door and go inside the Vigiflap. Use a mallet to disengage the latches 1 through 6 in order as shown in the image below. If the flap is in Floating Position, once all the latches are disengaged, the Vigiflap is ready. If the flap is in Locked Open Position, turn the springs out of the way and raise the arm as shown on page 17. Once the arm has been fully raised, put the springs back in place and lower the arm onto the springs.

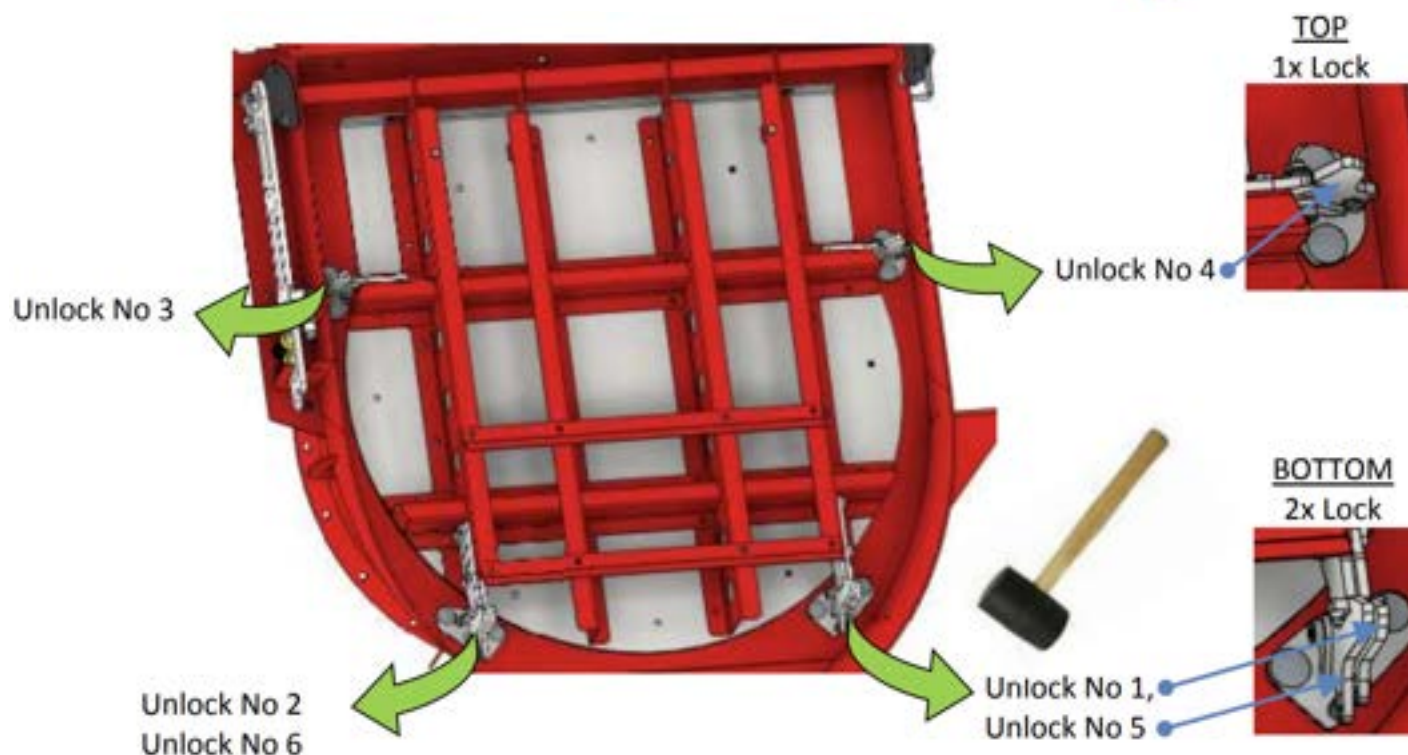
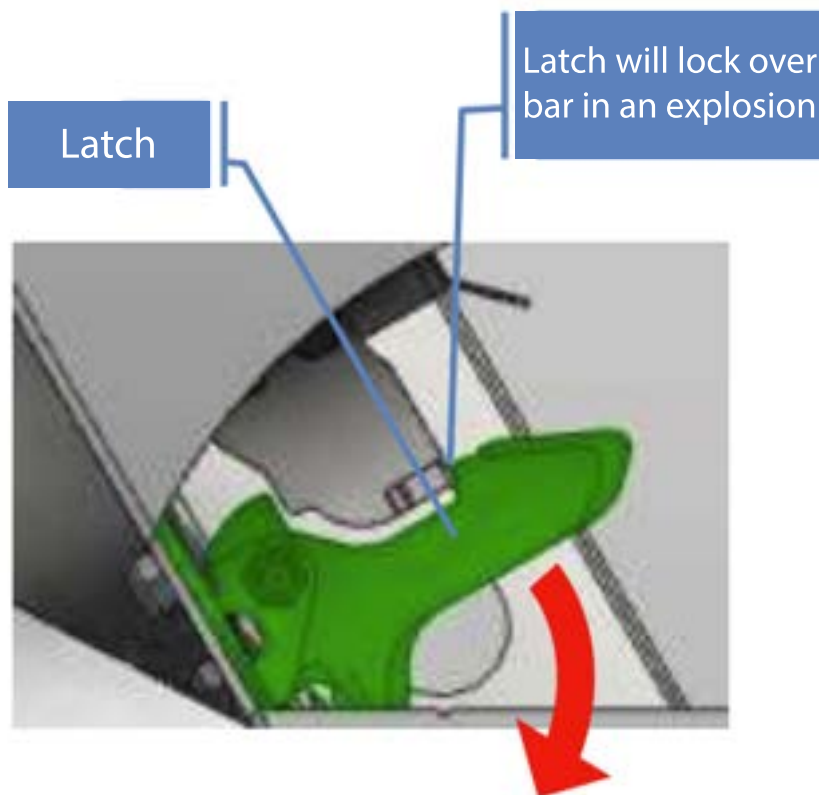

# CONTROL PANEL SPECIFICATIONS

## CP05 (56005-030000)

The CP05 is a powered relay which interprets signals from the Vigiflap and alerts the user to any faults or emergencies. Additionally, it intrinsically isolates the dust level sensor from the rest of the circuit so that neither fires nor surges from the dust sensor during an explosion can affect the rest of the circuit.

### 4 MODELS AVAILABLE\*

- Model: CP05 (1 Inlet, 1 Outlet)
- Model: CP05X2 (2 Inlets, 2 Outlets)
- Model: CP05X3 (3 Inlets, 3 Outlets)
- Model: CP05X4 (4 Inlets, 4 Outlets)
- \*Larger Panels are available upon request

### REQUIRED SENSORS

- Inductive Proximity Sensor: Comes Installed (40402-010000)
- Adjustable Dust Level Sensor: Capacitive sensor to ensure the VF is not compromised by a layer of organic dust accumulation, shipped loose (40409-010000)
- Metallic Dust Level Sensor: Inductive sensor to ensure the VF is not compromised by a layer of metallic dust accumulation, shipped loose (40409-020100)

### ALL MODELS FEATURE

- NEMA 4 Enclosure
- Status lights  
(Green = System OK / RED = System Trouble)
- Terminals for Inductive Proximity Sensor
- Intrinsic circuit with barrier Drawings
- 120VAC/24VDC Input Power
- UL 698A Intrinsically Safe Label



## RECEIVING THE VIGILEX VIGIFLAP



- The Vigilex VF typically ships shrink-wrapped and strapped on a wooden pallet. Customer must inspect the equipment for damage upon receipt. If damage is present, receiver must note damaged on the shipping documents in order to file a claim.
- Dependent on the size of the Vigiflap the CP05 control panel, and Adjustable Dust Level Sensor are shipped in a cardboard box placed on top of the valve or inside it.

### VF SHIPMENT PARTS

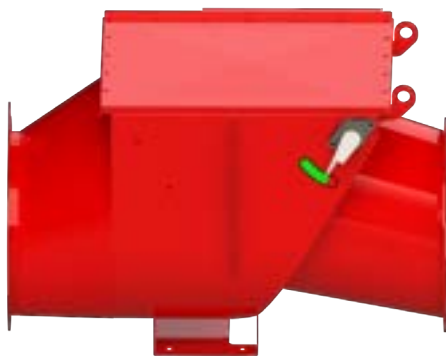

EV- VF Main Body



Pre-Installed Proximity Sensor



Adjustable Dust Level Sensor (recommended)

## MOUNTING SENSORS

### MOUNTING THE DUST LEVEL SENSOR TO VIGILEX VIGIFLAP



**STEP 1:** Remove bolt on the bottom side of the VF.

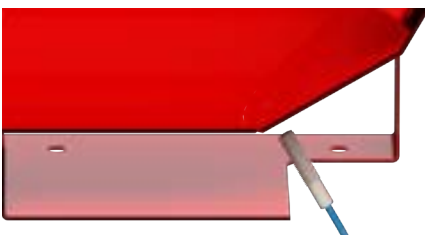

**STEP: 2:** Insert dust level sensor into exposed threaded hole



**STEP 3:** Screw sensor into hole until the depth achieved is 1.25" per image in step 3B

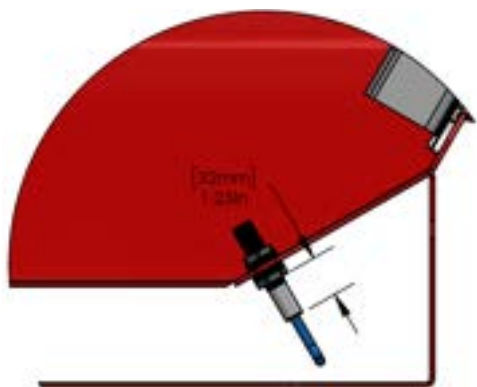

**STEP 3B:** If the tip of the sensor is too close to the bottom surface of the VF, the sensor will not function properly. Contrary, inserting the sensor too deep will result with interference from the flap valve.

**\*\*32mm/1.25in from the bottom surface of the exterior mounting flange to the bottom of the sensor.\*\***



**DUST LEVEL SENSOR:** The dust level sensor requires a shielded 2 conductor cable with a minimum of 18 ga. The cable should be run in its own conduit due to intrinsic safety.



**PROXIMITY SENSOR:** The proximity sensor requires a shielded 3 conductor cable with a minimum of 18 ga.

# GENERAL WIRING SCHEMATIC FOR THE CP05

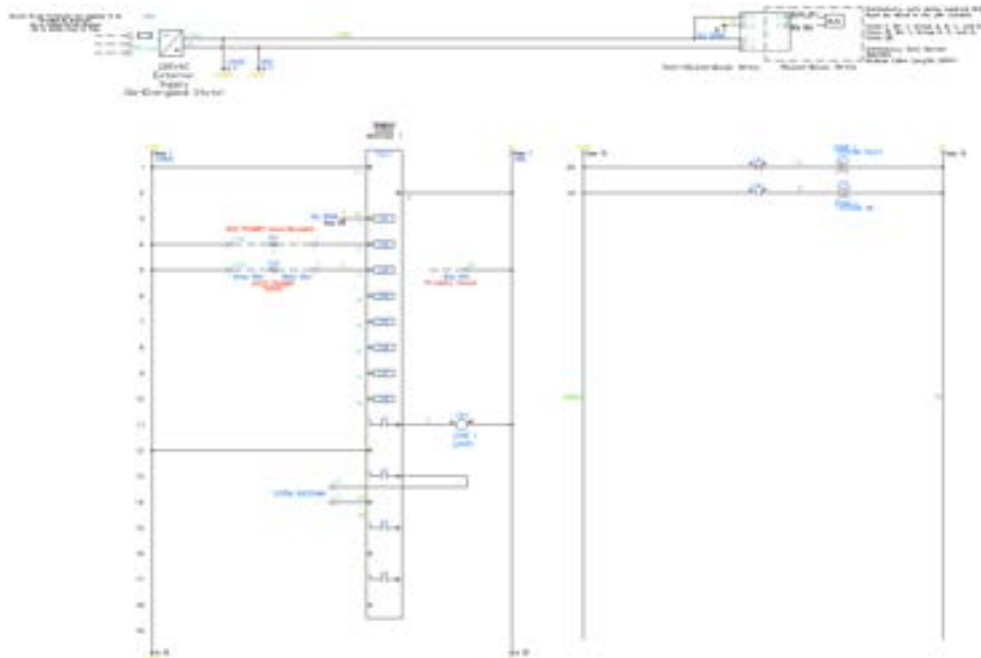

Larger and alternative wiring diagrams located in Appendix A

## WIRING THE DUST LEVEL SENSOR TO THE CP05

Connect the brown wire to terminal 4.1 on the intrinsic relay barrier. Connect the blue wire to terminal 4.3 on the intrinsic relay barrier.

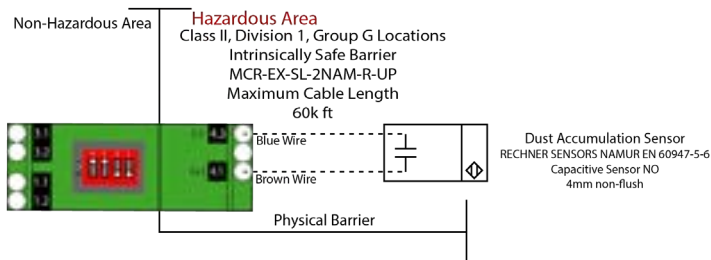

## WIRING THE PROXIMITY SENSOR

The brown wire will land in terminal “24V+”, the blue wire will land in terminal “0V”, and black wire will land in terminal “1” (See below)

Jumper will be required between “24V+” and “2” (See below)

## SYSTEM INTERLOCK VIA CP05

Terminals “U1” and “U2” will be used as a shut-down signal in the CP05. When the CP05 is “OK” the interlock contact will be closed. The contact will open if any sensor faults. (Refer to above schematic)

INLET PROXIMITY SENSOR CONNECTION

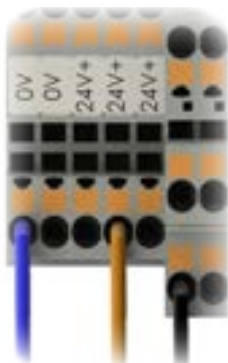

CONNECTION FOR CLEAN AIR VF (USE PROXIMITY SENSOR CONNECTIONS, JUMPER IF NOT USED)



SYSTEM INTERLOCK CONNECTION

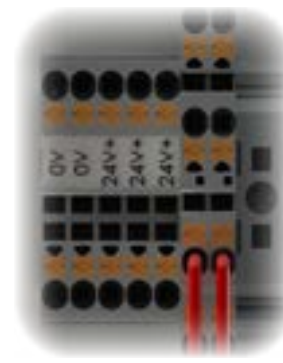

## BYPASSING THE DUST LEVEL SENSOR FOR INSPECTION PROTOCOL IN THE CP05

In cases where an inspection protocol (NFPA 69: 2019, 12.2.3.4.5.2) is instituted in lieu of a dust level sensor for dust accumulation monitoring inside of an VF the following instructions must be followed to ensure the system remains running uninterrupted by a fault alarm.

1. Press the Up or Down arrow until your screen displays the system time and then press the “ESC” key.



2. The system menu will come up, scroll using the Up and Down arrows and press the “OK” key when you find “Program”.



3. Under the “Program” menu, select “Set Parameter” by pressing the “OK” key.



4. Under the “Set Parameter” menu, select “Bypass DLS 1” and press the “OK” key.



5. Press the “OK” key until the word “Off” flashes. Scroll using the Up and Down arrows and change to “On”. Press “ESC” when complete to exit all menus. Repeat steps 4 and 5 for DLS 2, 3, and 4 (if applicable).



## MAINTENANCE AND INSPECTIONS

### FREQUENCY:

Frequency of maintenance depends on the application. After installation we recommend waiting 1 month before the first maintenance inspection. Use the first inspection to determine a more accurate frequency of maintenance. The maximum time between inspections should not be greater than one year.

### PROCEDURE:

1. Shut off the fan and air flow to the Vigiflap before performing an inspection.
2. Remove the side safety cover and the top access panel.
3. Check for dust build up by inspecting the inside of the Vigiflap and clean out dust if build up is occurring.
4. Inspect the flap and inside of the body for abrasive, corrosive, or impact damage. Replace parts as needed.
5. Verify that the flap locks in the closed position and that the proximity switch triggers when it does so.
6. Check the duct connection to ensure that all bolts and nuts are properly tightened.
7. Test the dust level sensor by covering it for 5 seconds and making sure that the alarm triggers.

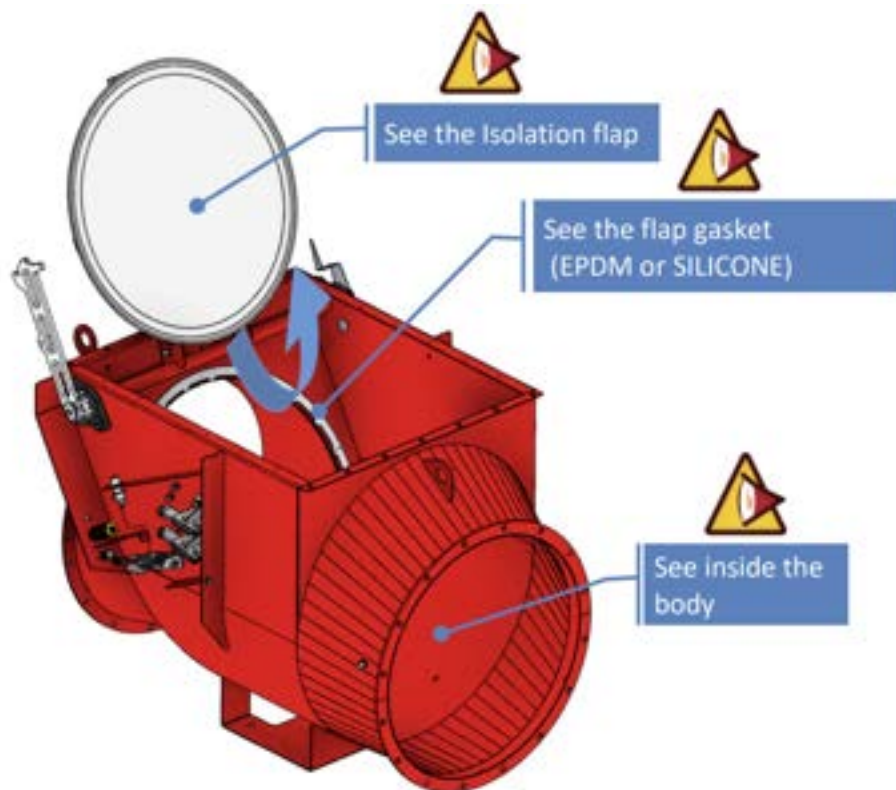

### EXPLOSION:

After a triggering incident with the Vigiflap, the body has to be thoroughly inspected by a dedicated technician to ensure the Vigiflap has not undergone damage from the shock. It is not safe to run the Vigiflap until this inspection is completed.

## FREQUENTLY ASKED QUESTIONS

1. Can I install the dust level sensor after the Vigiflap has already been installed?
  - ▷ Yes, use access door on top of the Vigiflap to install interior mounting flange of the dust level sensor. Refer to page 22.
2. How do I know if I have a CP05 or CP04 control panel?
  - ▷ Every control panel has a sticker on the door indicating the model. If sticker is missing or damaged, an easy way of telling the difference is : CP05s have a gray enclosure with a printed decal on the front and CP04s have a red enclosure.
3. How do I wire the dust level sensor to the control panel?
  - ▷ Connect the brown wire to terminal 4.1 on the intrinsic relay barrier. Connect the blue wire to terminal 4.3 on the intrinsic relay barrier. Refer to page 23.
4. How do I wire the proximity sensor to the control panel?
  - ▷ The brown wire will land in the “24V+” terminal, the black wire will land in the “1” terminal, and the blue wire will land in the “0V” terminal. Refer to page 23.
5. What is the installation depth of the dust level sensor in the Vigiflap?
  - ▷ It is recommended to have 32mm/1.25in from the bottom surface of the exterior mounting flange to the bottom of the sensor for proper functionality. Refer to page 22.

## TROUBLESHOOTING GUIDE

1. My dust level sensor keeps throwing a system fault.
  - ▷ Visually inspect the inside of the Vigiflap to ensure there is no dust accumulation and/or liquid causing the dust level sensor to trip. In cases where it is impossible to eliminate the problem, removing the sensor and instituting a documented inspection protocol is acceptable to achieve NFPA compliance. Refer to page 16 on how to bypass the dust level sensor.
2. I believe I have the dust level sensor wired correctly but I want to test it to ensure functionality before installing it in the Vigiflap.
  - ▷ Press the top of the sensor lightly with finger for 10 to 15 seconds. If wired properly, this will trip the sensor and cause the red light on the control panel to come on indication “system fault”. You can then proceed to installing the dust level sensor following steps on page 22.

## VF SPARE/REPLACEMENT PARTS



CP05 Control Panel  
P/N: 56005-030000



Dust Level Sensor  
P/N: 40409-010000

or

Metallic Dust Level Sensor  
P/N: 40409-020100



Proximity Sensor  
P/N: 40402-010000





# APPENDIX A: WIRING DIAGRAMS

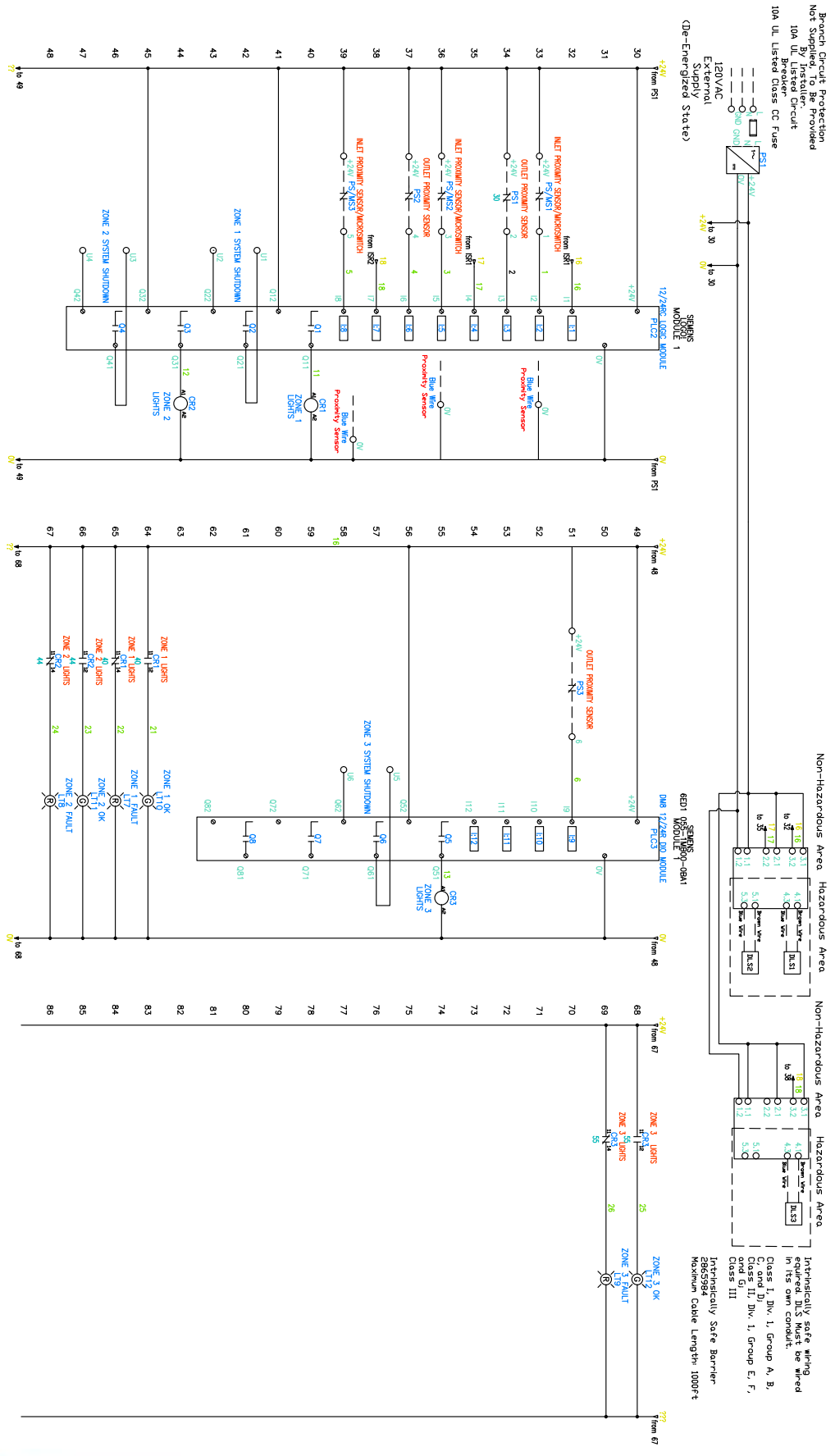

Boss Products LLC 6729 Guada Coma Dr. Schertz TX, 78154 210-664-4200		Title: CP05X3 DWG No.: CP05 Page: 1	
Horsepower:	NA	Voltage (V):	120VAC/24VDC
SCCR (KVA):	5	Amperage (A):	5
Phase:	1	Frequency (Hz):	60
Rev:	0	Date:	12/24/2022
		Description:	Digital Release



6729 Guada Coma Dr.  
 Schertz, TX 78154  
 M: 210-664-4200  
 F: 210-664-4220  
 info@bossproductamerica.com

# APPENDIX A: WIRING DIAGRAMS

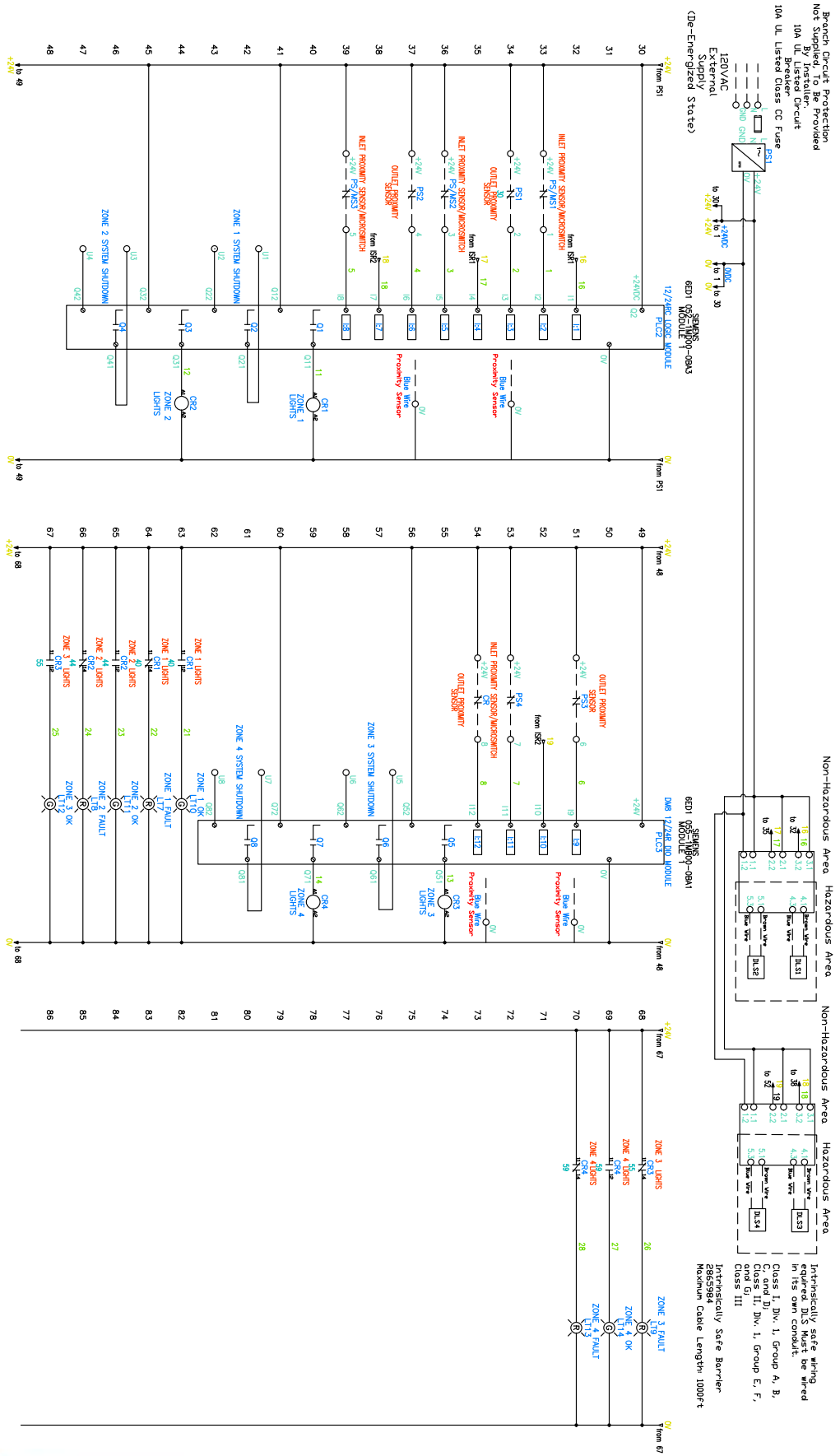

Boss Products LLC  
6729 Guada Coma, Dr.  
Schertz, TX, 78154  
210-664-4200

Title: CP05x4  
DWG No.: CP05  
Page: 1

Horsepower:	NA	Voltage (V):	120VAC/24VDC
SCCR (KAY)	5	Amperage (A):	5
Phase:	1	Frequency (Hz):	60

Rev	Date	Description
0	12/14/2023	Original Release



6729 Guada Coma Dr.  
Schertz, TX 78154  
M: 210-664-4200  
F: 210-664-4220  
info@bossproductamerica.com

## APPENDIX B: WIRING GRAPHIC

### SINGLE ZONE CP05 WIRING

CASE 1: 1X VIGIFLAP ON DIRTY SIDE, 1X VIGIFLAP ON CLEAN SIDE

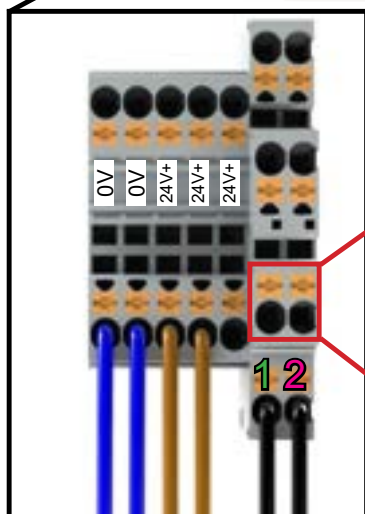

U1 AND U2  
INTERLOCK -  
TO BE USED AS A  
SHUTDOWN SIGNAL

PROXIMITY SENSORS WIRING:

**BLUE** WIRES: 0V

**BROWN** WIRES: 24V+

**BLACK** WIRE FROM DIRTY SIDE VF: TERMINAL "1"

**BLACK** WIRE FROM CLEAN SIDE VF: TERMINAL "2"

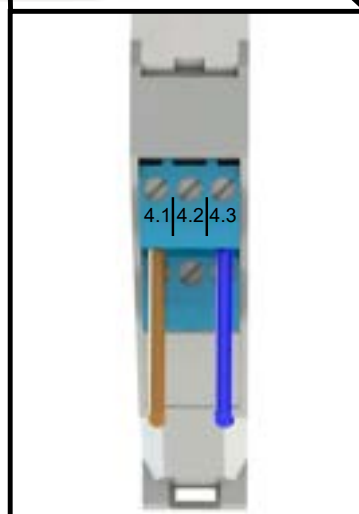

DUST LEVEL SENSOR WIRING:

**BROWN** WIRE: 4.1 TERMINAL

**BLUE** WIRE: 4.3 TERMINAL

\* DIRTY SIDE VIGIFLAP ONLY \*

## APPENDIX B: WIRING GRAPHIC

### SINGLE ZONE CP05 WIRING

CASE 2: 1X VIGIFLAP ON DIRTY SIDE, NO VIGIFLAP ON CLEAN SIDE

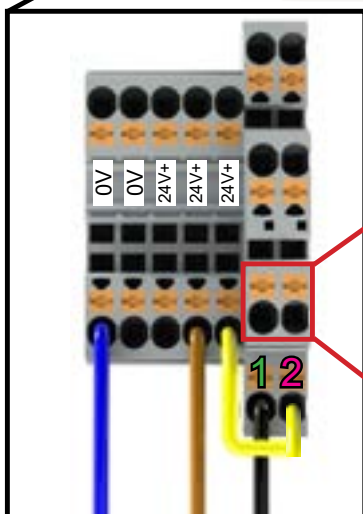

U1 AND U2  
INTERLOCK -  
TO BE USED AS A  
SHUTDOWN SIGNAL

PROXIMITY SENSOR WIRING:

- BLUE** WIRE: 0V
- BROWN** WIRE: 24V+
- BLACK** WIRE: TERMINAL "1"
- YELLOW** JUMPER: 24V+ TO TERMINAL "2"

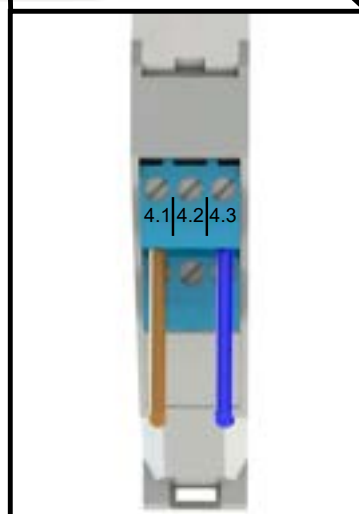

DUST LEVEL SENSOR WIRING:

- BROWN** WIRE: 4.1 TERMINAL
  - BLUE** WIRE: 4.3 TERMINAL
- \* DIRTY SIDE VIGIFLAP ONLY \*

## APPENDIX B: WIRING GRAPHIC

### 2 ZONE CP05 WIRING

#### CASE 3: 2X VIGIFLAPS ON DIRTY SIDE, 2X VIGIFLAPS ON CLEAN SIDE

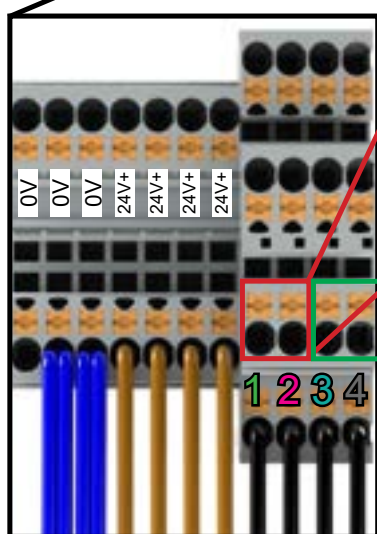

PROXIMITY SENSORS WIRING:

**BLUE** WIRES: 0V

**BROWN** WIRES: 24V+

**BLACK** WIRE FROM DIRTY SIDE VF (**ZONE 1**): TERMINAL "1"

**BLACK** WIRE FROM CLEAN SIDE VF (**ZONE 1**): TERMINAL "2"

**BLACK** WIRE FROM DIRTY SIDE VF (**ZONE 2**): TERMINAL "3"

**BLACK** WIRE FROM CLEAN SIDE VF (**ZONE 2**): TERMINAL "4"

U1 AND U2 (ZONE 1)  
INTERLOCK -  
TO BE USED AS A SHUT-  
DOWN SIGNAL

U3 AND U4 (ZONE 2)  
INTERLOCK -  
TO BE USED AS A SHUT-  
DOWN SIGNAL

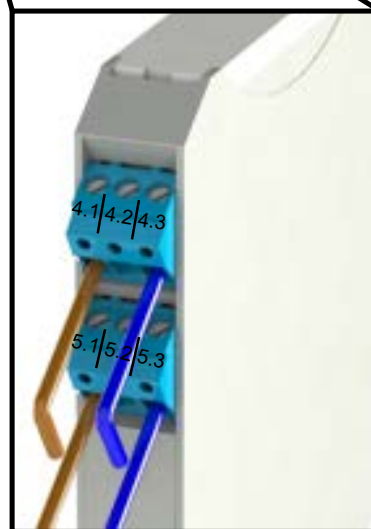

DUST LEVEL SENSORS WIRING:

**ZONE 1:**

**BROWN** WIRE: 4.1 TERMINAL

**BLUE** WIRE: 4.3 TERMINAL

**ZONE 2:**

**BROWN** WIRE: 5.1 TERMINAL

**BLUE** WIRE: 5.3 TERMINAL

\* DIRTY SIDE VIGIFLAPS ONLY \*

## APPENDIX B: WIRING GRAPHIC

### 2 ZONE CP05 WIRING

#### CASE 4: 2X VIGIFLAPS ON DIRTY SIDE, 1X VIGIFLAP ON CLEAN SIDE

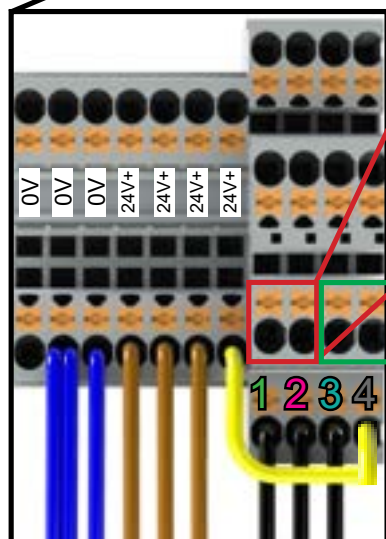

U1 AND U2 (ZONE 1)  
INTERLOCK -  
TO BE USED AS A SHUT-  
DOWN SIGNAL

U3 AND U4 (ZONE 2)  
INTERLOCK -  
TO BE USED AS A SHUT-  
DOWN SIGNAL

#### PROXIMITY SENSORS WIRING:

**BLUE** WIRES: 0V

**BROWN** WIRES: 24V+

**BLACK** WIRE FROM DIRTY SIDE VF (**ZONE 1**): TERMINAL "1"

**BLACK** WIRE FROM CLEAN SIDE VF (**ZONE 1**): TERMINAL "2"

**BLACK** WIRE FROM DIRTY SIDE VF (**ZONE 2**): TERMINAL "3"

**YELLOW** JUMPER (**ZONE 2**): 24V+ TO TERMINAL "4"

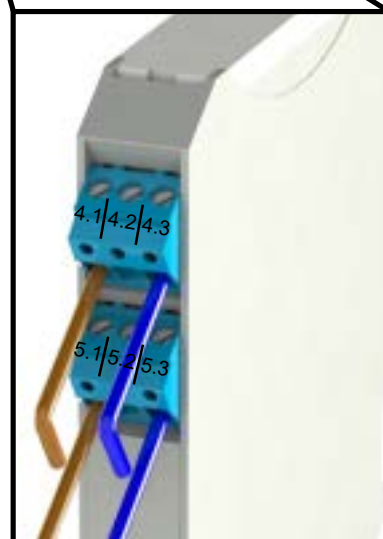

#### DUST LEVEL SENSORS WIRING:

##### **ZONE 1:**

**BROWN** WIRE: 4.1 TERMINAL

**BLUE** WIRE: 4.3 TERMINAL

##### **ZONE 2:**

**BROWN** WIRE: 5.1 TERMINAL

**BLUE** WIRE: 5.3 TERMINAL

\* DIRTY SIDE VIGIFLAPS ONLY \*

## APPENDIX B: WIRING GRAPHIC

### 2 ZONE CP05 WIRING

#### CASE 5: 2X VIGIFLAPS ON DIRTY SIDE, NO VIGIFLAP ON CLEAN SIDE

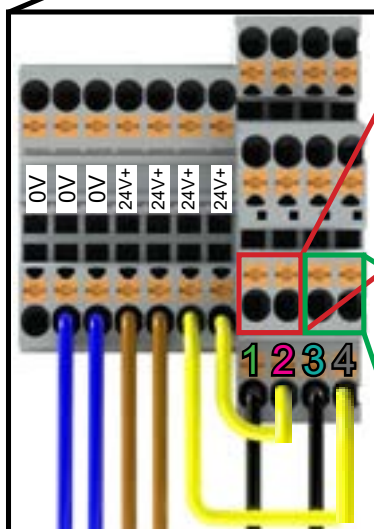

U1 AND U2 (ZONE 1)  
INTERLOCK -  
TO BE USED AS A SHUT-  
DOWN SIGNAL

U3 AND U4 (ZONE 2)  
INTERLOCK -  
TO BE USED AS A SHUT-  
DOWN SIGNAL

PROXIMITY SENSORS WIRING:

**BLUE** WIRES: 0V

**BROWN** WIRES: 24V+

**BLACK** WIRE FROM DIRTY SIDE VF (**ZONE 1**): TERMINAL "1"

**YELLOW** JUMPER (**ZONE 1**): 24V+ TO TERMINAL "2"

**BLACK** WIRE FROM DIRTY SIDE VF (**ZONE 2**): TERMINAL "3"

**YELLOW** JUMPER (**ZONE 2**): 24V+ TO TERMINAL "4"

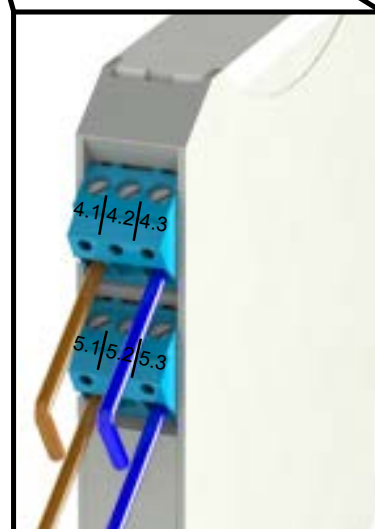

DUST LEVEL SENSORS WIRING:

**ZONE 1:**

**BROWN** WIRE: 4.1 TERMINAL

**BLUE** WIRE: 4.3 TERMINAL

**ZONE 2:**

**BROWN** WIRE: 5.1 TERMINAL

**BLUE** WIRE: 5.3 TERMINAL

\* DIRTY SIDE VIGIFLAPS ONLY \*

# Craig Equipment Company

13055 MIDDLETOWN INDUSTRIAL BLVD, LOUSBILLE, KY 40223  
TF:800-928-7100 • T:502-245-4840 • F:502-245-1665 [craig-equip.com](http://craig-equip.com)

