

Donaldson
Torit®

**TRUNK 2000™
FUME COLLECTOR**
MODEL T-2000

ULTRA-WEB®
High Efficiency **Fine Fiber Filters** Built to Last

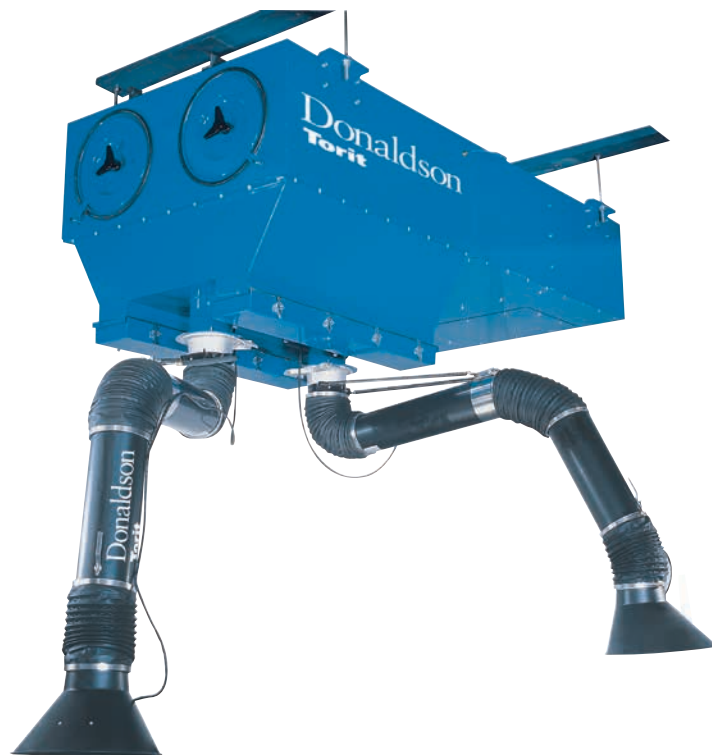

T-2000

A self-contained source collector designed to capture fume generated from moderate-to-heavy welding applications.

- Designed to handle one or two welding stations using Ex-Arms
- Ceiling-mount configuration saves valuable plant floor space and provides optimum range of the Ex-Arms
- FLUENT®* designed inlet and dust hopper minimizes fume re-entrainment and reduce maintenance expense
- Automatic pulse-cleaning system for continuous welding operations
- Proprietary filter cleaning system lengthens filter life
- Ultra-Web® FR filter cartridges featuring fine fiber technology provide high filtration efficiency and long filter life
- MERV** 15 filtration efficiency rating per ASHRAE 52.2-2007
- Recirculation of clean air reduces need for costly make-up air

* FLUENT is a registered trademark of Fluent, Inc.

** The Minimum Efficiency Reporting Value (MERV) of this filter cartridge has been determined through independent laboratory testing using ASHRAE 52.2 (2007) test standards. The MERV rating was determined at a face velocity of 118 feet per minute (36.0 meters per minute) and loading up to four inches (101.6 mm) water gauge. Actual efficiency of any filter cartridge will vary according to the specific application parameters. Dust concentration, airflow, particle characteristics, and pulse cleaning methods all affect filtration efficiency.

Dimensions & Specifications

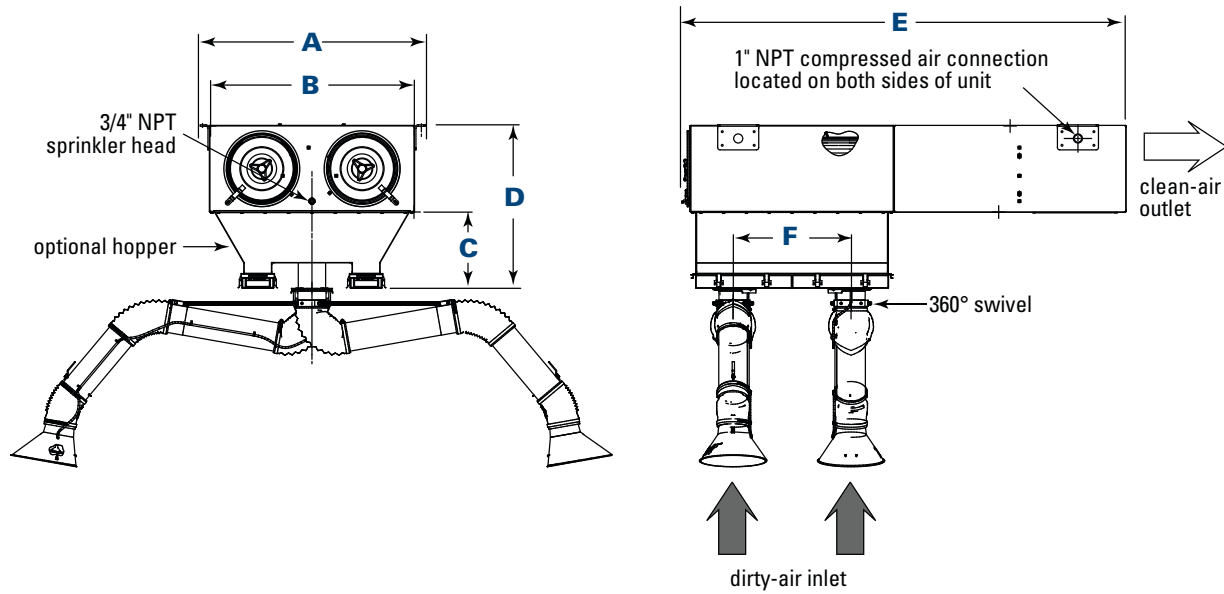

Model	Nominal Airflow*		No. of Filters (Ultra-Web FR)	Filter Area		No. of 3/4" Valves	Dimensions								Shipping Weight		Sound Level dB(A)†					
							A		B		C		D						E		F	
	cfm	m³/h		ft²	m²		in	mm	in	mm	in	mm	in	mm	in	mm	in	mm	lb	kg	Fan	Pulse
T-2000	890	1512	4	636	59.1	2	50.0	1270.0	45.0	1143.0	16.9	429.3	35.9	911.9	97.4	2474.0	25.9	657.9	790	358.3	71	80.5

STANDARD FEATURES & AVAILABLE OPTIONS

STANDARD	OPTIONAL
Ultra-Web® FR cartridges	Ex-Arm - 6.5 ft (2 m), 10 ft (3.0 m), 13 ft (4.0 m)
5 hp TEFC motor	Magnehelic®** gauge
One (1) Ex-Arm with light	Photohelic®** gauge
Sprinkler head	Hopper with re-entrainment baffles and four removal dust pans
110 VAC control box 208/230/460/60/3 voltage	Solenoid valve silencer
10-year warranty	<small>*Based on clean filters, per Ex-Arm. **Magnehelic and Photohelic are registered trademarks of Dwyer Instruments, Inc. †db(A) sound levels are an average of measurements made in a laboratory environment. Installed sound levels will vary depending on the measurement location, operating conditions, and installation.</small>

Significantly improve the performance of your collector with genuine Donaldson Torit replacement filters and parts.

Important Notice

Many factors beyond the control of Donaldson can affect the use and performance of Donaldson products in a particular application, including the conditions under which the product is used. Since these factors are uniquely within the user's knowledge and control, it is essential the user evaluate the products to determine whether the product is fit for the particular purpose and suitable for the user's application. All products, product specifications, availability and data are subject to change without notice, and may vary by region or country.



Craig Equipment Company

13055 MIDDLETOWN INDUSTRIAL BLVD. LOUISVILLE, KY 40223 • P.O. BOX 43250 LOUISVILLE, KY 40253

TF: 800-928-7100 • T: 502-245-4840 • F: 502-245-1665

craig-equip.com