

# Hartzell

AIR MOVEMENT

## Fiberglass Air Control Products

SERIES FFL, FEP, FLC, FLO, FCP



Craig Equipment Company

13055 MIDDLETOWN INDUSTRIAL BLVD, LOUISVILLE, KY 40223  
TF: 800-928-7100 • T: 502-245-4840 • F: 502-245-1665 • [craig-equip.com](http://craig-equip.com)



# THE HARTZELL DIFFERENCE

Building the highest quality fans in America for generations



## QUALITY AT EVERY TURN.

Hartzell Air Movement exceeds the standard in the air movement industry, committed to delivering top-quality, reliable products. And our relationship with our customers, and our knowledgeable, inventive, flexible and hardworking employees are the reasons we've continued and thrived, right here in the USA, for six generations.

### Customers choose Hartzell for our:

- Durability and high performance
- Low cost of ownership
- Leadership in performance testing and certification
- Advanced engineering and manufacturing processes
- Innovative design and manufacturing
- Trusted brand name

### Experienced Hartzell team to assist you from design to shipping

ISO 9001:2015 Certification  
AMCA Accredited Laboratory  
Complete Fans and Blowers  
Centrifugal Wheels  
Airfoil Propellers



## HARTZELL ADVANTAGES

### A LIFETIME OF VALUE

- Industrial fans are field proven, 100% tested, with virtually no incident of return
- Energy efficient designs that provide a lower total cost of ownership

### LEADERSHIP IN PERFORMANCE

- Products certified by AMCA that meet DOE recommended efficiencies
- Highly efficient industrial fan designs that are the quietest in the market
- Airfoil shape blades with industry leading measured efficiencies

### ADVANCED ENGINEERING & MANUFACTURING

- Proven manufacturing techniques on state of the art equipment in ISO 9001:2015 registered facilities
- Engineering team utilizes the latest design tools in 3D CAD and other modeling software

### CREATIVE DESIGN & MANUFACTURING TEAM

- Offering the greatest number of industrial fan design choices
- Building products to meet your rigorous application; no limiting catalog

### TRUSTED BRAND NAME

- Extensive talent pool bringing over 145 years of knowledge and experience to you

### 5-YEAR WARRANTY

- The industry's first and only manufacturer that stands behind their products for a full 5-years



- Register your 5 year warranty
- Download your installation manual
- Order replacement parts



For more information, contact your local Hartzell Sales Representative. [info@hartzell.com](mailto:info@hartzell.com)

---

# HARTZELL WARRANTY

LIMITED WARRANTIES, LIMITATION OF LIABILITY, AND  
LIMITATION OF LIABILITY FOR BREACH OF WARRANTY

## NO IMPLIED WARRANTIES OF MERCHANTABILITY OR FITNESS

Hartzell does not warrant that said goods are of merchantable quality or that they are fit for any particular purpose. There is no implied warranty of merchantability and there is no implied warranty of fitness.

The details of the Hartzell warranty can be found at  
<http://www.hartzellairmovement.com/warranty-service>

---

# PERFORMANCE GUARANTEED

Your products are only as good as the components that go into them. We know you have high expectations, and so does Hartzell Air Movement. We know you expect the most reliable and durable industrial air movement products available, so we're holding ourselves to a higher standard. We're so sure that our products will out-perform industry standards, we're backing that promise with the industry's first – and only – five-year warranty.

At Hartzell, these are words we live by. They guide us every day. Good enough isn't how you design your products. It's not how we engineer, build and support our products — or provide ongoing service to our customers. When we looked at the industry standard two-year warranty, we knew we had to do better. And we did — by offering the Hartzell **FIVE-YEAR WARRANTY**.

Register for your 5year warranty at  
<https://www.hartzellairmovement.com/warranty-and-parts/five-year-warranty>

---

Hartzell Air Movement  
proudly manufactures  
our fans right here in  
the USA!



**MADE IN  
U.S.A.**

## Content

|   |    |
|---|----|
| <b>Options &amp; Accessories</b>                                  | 5  |
| <b>Fixed Blade Drainable Louver</b><br>Series FFL                 | 6  |
| <b>End-Pivoted Automatic Shutter</b><br>Series FEP                | 8  |
| <b>Low Velocity Center-Pivoted Damper</b><br>Series FLC           | 10 |
| <b>Center-Pivoted Volume Control Damper</b><br>Series FCO and FCP | 12 |

# ADVANTAGES OF FIBERGLASS CONSTRUCTION

A variety of corrosion problems plague the water and wastewater industry. Although fans and blowers made of coated steel or metals such as stainless, Hastelloy and monel can handle some of these challenges, Hartzell's fiberglass products provide unsurpassed resistance to a great majority of corrosive elements at a cost substantially below that of corrosion resistant metals.

## ADVANTAGES

### ✓ FIBERGLASS OFFERS SUPERIOR CORROSION RESISTANT PROPERTIES

- ✓ Weighs 25% - 50% less than comparable equipment made of metal alloys
- ✓ Has an extremely high strength-to-weight ratio, stronger than steel on a per-pound basis
- ✓ Has excellent dimensional stability
- ✓ Will not become brittle at low temperatures and at -40°F laminated fiberglass will be stronger than at room temperature
- ✓ Offers a distinct price advantage over stainless and Monel (as much as 1/3 in original cost)
- ✓ Has a longer service life and requires less maintenance
- ✓ Offers weather-resistant characteristics – it will not tarnish and will never need painting
- ✓ Is extremely durable and highly resistant to impact

When optional surface veil, electrical grounding and dynamic balancing are applied, Hartzell Air Movement conforms to ASTM D4167-21 and ASTM E84-2008 Standard Specifications for Fiber-Reinforced Plastic (FRP) Fans and Blowers.

# SUPERIOR CORROSION RESISTANCE

## RESIN TRANSFER MOLDED



Hartzell offers the *ONLY* fiberglass wheels & propellers available in a solid, one-piece design from the mold.

- ✓ Solid, one-piece design from an RTM mold – up to 60" dia.
- ✓ Consistent wheels and propellers with 98%+ exact wheels and propellers. Only variation is in the requested finishes.
- ✓ Repeatable Process
- ✓ Available in 12" - 60" diameters
- ✓ Much stronger wheels and propellers

Hartzell's fiberglass wheels and propellers are unique in the fan and blower industry.

They are manufactured as a single fiberglass piece using a multi-section RTM mold, ensuring that each wheel and prop is aerodynamically identical and provides reliable, repeatable performance without the variability of hand-made and taped components.

The superior design is a result of a substantial investment in research, development, tooling, and manufacturing methods by Hartzell Air Movement.

# Options and Accessories

## Abrasive/Erosive Resistant Coating

HartKoate is an abrasive/erosive resistant coating developed by Hartzell Air Movement for application in environments where abrasive/erosive conditions may exist. HartKoate helps prevent premature deterioration of equipment in environments where uncoated fans may fail.

HartKoate is applied to a 50-60 mil thickness suitable for temperatures to 200°F.

HartKoate is particularly appropriate for use when water mist and/or abrasive particles exist in the airstream.

Contact your Hartzell representative for further details concerning the application of HartKoate coating to fiberglass fans in corrosive atmospheres.

## Hi-Cor Construction

All airstream surfaces exposed to corrosive environment will be protected with a layer of Synthetic (Nexus) surfacing veil. An additional final coat of resin will be applied for extra corrosion resistance.

When Hi-Cor construction is required, the factory should be consulted concerning the corrosive environment involved.

## Electrostatically Grounded

For applications in which fiberglass products are handling gas fumes that are not only corrosive but also potentially explosive, the equipment should be specially constructed to control and remove static electricity. Interior airstream surfaces can be coated with a "carbon rich" resin coat.

Grounding straps are secured from the side of the frame. All that remains to effectively ground the part is to ground the frame at the time of installation.

## Insect Screen

Stainless steel screen.

## Fiberglass Bird Screen

Fiberglass screen with larger openings than insect screen.

## Fiberglass Mounting Angle

Facilitates mounting in the wall.

## Blade Seals

Minimizes leakage at the blade overlaps.

## Jamb Seals

Minimizes leakage at the blade ends.

## Inlet and Outlet Guards

Inlet and outlet guards are available for fiberglass dampers and louvers. OSHA approved. Available in stainless steel, epoxy coated steel or fiberglass construction.

## Manual Operators and Locking Quadrants

Available mounted to control dampers.

## Motor Operators and Actuators

Available in electric or pneumatic with options per customer specifications.



*Series FFL Fiberglass Louver at a Wastewater Treatment Plant*

# Performance Guaranteed



Your products are only as good as the components that go into them. We know you have high expectations, and so does Hartzell Air Movement. We know you expect the most reliable and durable industrial air movement products available, so we're holding ourselves to a higher standard. We're so sure that our products will out-perform industry standards, we're backing that promise with the industry's first – and only – five-year warranty.

At Hartzell, these are words we live by. They guide us every day. Good enough isn't how you design your products. It's not how we engineer, build and support our products — or provide ongoing service to our customers. When we looked at the industry standard two-year warranty, we knew we had to do better. And we did — by offering the Hartzell **FIVE-YEAR WARRANTY**.

# Series FFL

## Fiberglass Fixed Blade Drainable Louver

Constructed entirely of fiberglass, the Series FFL Fiberglass Fixed Blade Drainable Louver is recommended for air intake, exhaust or pressure relief applications where corrosive elements exist in fume or vapor form.

### Advantages of Fiberglass Construction:

- Superior corrosion resistance
- Excellent dimensional stability - It will not become brittle at low temperatures and at 0°F, laminated fiberglass will be stronger than at room temperature
- Strength-to-weight ratio 43% greater than that of aluminum

### Features:

- **FRP Construction** - All parts are constructed of fiberglass and isophthalic vinyl resin with a Class I flame spread rate of 25 or less and utilize woven fiberglass mat material for superior strength. All surfaces are protected for ultra-violet resistance. Joints are bonded with an industrial grade epoxy adhesive, having similar corrosion resistant properties as a vinyl ester resin.
- **Sizes** - Available in standard and custom sizes
- **Temperature** - Suitable for temperatures up to 200°F
- **Maximum Free Area Inlet Velocity** - 825 FPM
- **Maximum Louver Size** - 72" W x 72" H. Larger units are available in multiple panel construction with special reinforced manufacturing techniques.
- **Minimum Louver Size** - 12" W x 12" H
- **Frame** - 4" x 1 1/16" x 1/8" fiberglass reinforced isophthalic vinyl resin
- **Blades** - Minimum .070" thick fiberglass reinforced isophthalic vinyl resin
- **Draining** - Blades drain to either side with runoff discharged at bottom of louver.
- **Color** - Medium gray is standard. Other colors available upon request.
- **Mounting Configurations** - Available in angle or flange mount. Angle mounts are used for deep walls and flange mounts are used for narrow walls. Please check local building codes for specific installation requirements applicable to the project.



### Ratings for Air Performance & Leakage

Hartzell Air Movement certifies that the Series FFL Fiberglass Fixed Blade Drainable Louver air performance ratings shown herein are reliable and accurate and in accordance with industry standards. Ratings are based on tests and procedures performed in accordance with AMCA Standard 500.

## Performance Data

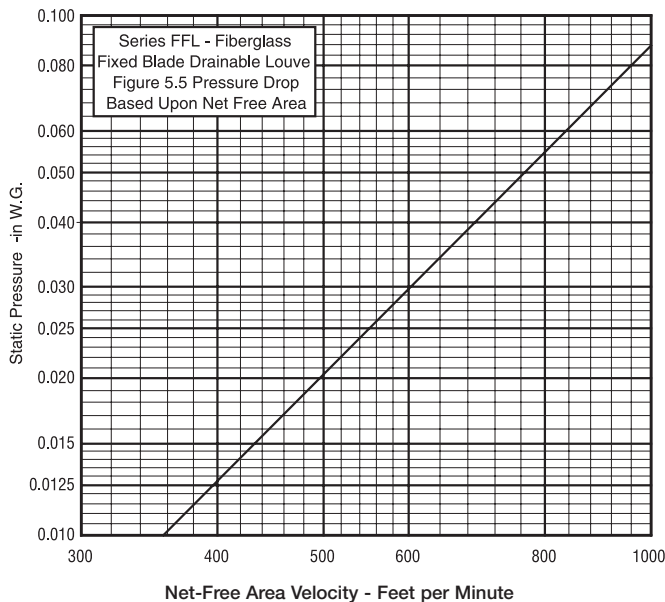

# Dimensions: Series FFL

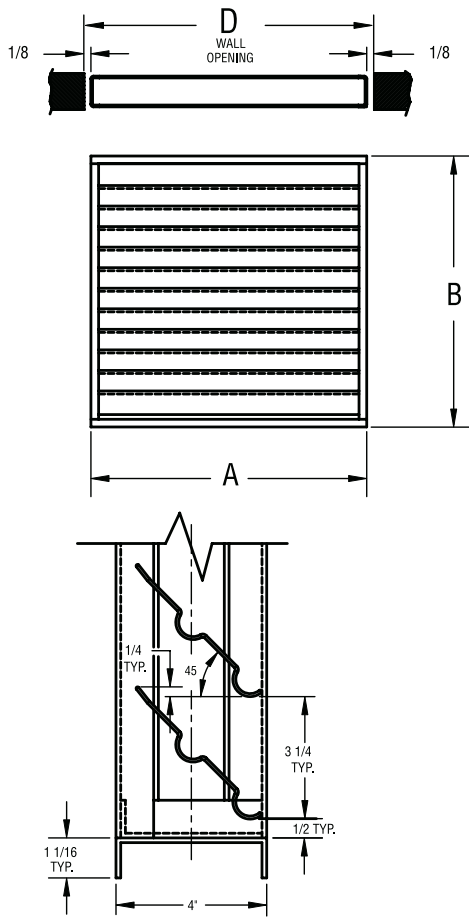

## Dimensions (inches)

| Fan Size | A  | B  | C                              | D                              |
|----------|----|----|--------------------------------|--------------------------------|
| 12       | 12 | 12 | 12 <sup>1</sup> / <sub>4</sub> | 12 <sup>1</sup> / <sub>4</sub> |
| 14       | 14 | 14 | 14 <sup>1</sup> / <sub>4</sub> | 14 <sup>1</sup> / <sub>4</sub> |
| 16       | 16 | 16 | 16 <sup>1</sup> / <sub>4</sub> | 16 <sup>1</sup> / <sub>4</sub> |
| 18       | 18 | 18 | 18 <sup>1</sup> / <sub>4</sub> | 18 <sup>1</sup> / <sub>4</sub> |
| 20       | 20 | 20 | 20 <sup>1</sup> / <sub>4</sub> | 20 <sup>1</sup> / <sub>4</sub> |
| 22       | 22 | 22 | 22 <sup>1</sup> / <sub>4</sub> | 22 <sup>1</sup> / <sub>4</sub> |
| 24       | 24 | 24 | 24 <sup>1</sup> / <sub>4</sub> | 24 <sup>1</sup> / <sub>4</sub> |
| 26       | 26 | 26 | 26 <sup>1</sup> / <sub>4</sub> | 26 <sup>1</sup> / <sub>4</sub> |
| 28       | 28 | 28 | 28 <sup>1</sup> / <sub>4</sub> | 28 <sup>1</sup> / <sub>4</sub> |
| 30       | 30 | 30 | 30 <sup>1</sup> / <sub>4</sub> | 30 <sup>1</sup> / <sub>4</sub> |
| 32       | 32 | 32 | 32 <sup>1</sup> / <sub>4</sub> | 32 <sup>1</sup> / <sub>4</sub> |
| 36       | 36 | 36 | 36 <sup>1</sup> / <sub>4</sub> | 36 <sup>1</sup> / <sub>4</sub> |
| 40       | 40 | 40 | 40 <sup>1</sup> / <sub>4</sub> | 40 <sup>1</sup> / <sub>4</sub> |
| 42       | 42 | 42 | 42 <sup>1</sup> / <sub>4</sub> | 42 <sup>1</sup> / <sub>4</sub> |
| 44       | 44 | 44 | 44 <sup>1</sup> / <sub>4</sub> | 44 <sup>1</sup> / <sub>4</sub> |
| 48       | 48 | 48 | 48 <sup>1</sup> / <sub>4</sub> | 48 <sup>1</sup> / <sub>4</sub> |
| 54       | 54 | 54 | 54 <sup>1</sup> / <sub>4</sub> | 54 <sup>1</sup> / <sub>4</sub> |
| 60       | 60 | 60 | 60 <sup>1</sup> / <sub>4</sub> | 60 <sup>1</sup> / <sub>4</sub> |
| 72       | 72 | 72 | 72 <sup>1</sup> / <sub>4</sub> | 72 <sup>1</sup> / <sub>4</sub> |

## Angle Mount

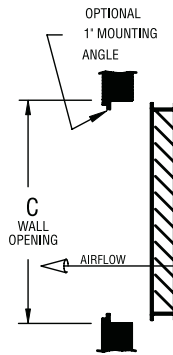

## Flange Mount

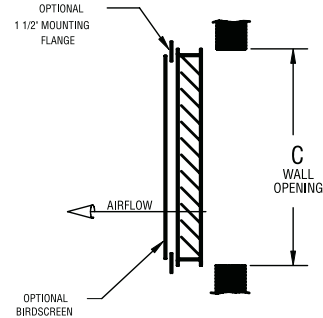

## Free Area In Square Feet

|    | Width |      |      |      |      |      |      |      |      |      |      |      |       |       |       |       |       |       |       |
|----|-------|------|------|------|------|------|------|------|------|------|------|------|-------|-------|-------|-------|-------|-------|-------|
|    | 12    | 14   | 16   | 18   | 20   | 22   | 24   | 26   | 28   | 30   | 32   | 36   | 40    | 42    | 44    | 48    | 54    | 60    | 72    |
| 12 | .40   | .48  | .56  | .65  | .73  | .81  | .89  | .97  | 1.05 | 1.13 | 1.21 | 1.38 | 1.54  | 1.62  | 1.70  | 1.87  | 1.96  | 2.21  | 2.70  |
| 14 | .41   | .50  | .58  | .66  | .75  | .83  | .91  | 1.0  | 1.08 | 1.16 | 1.25 | 1.41 | 1.58  | 1.66  | 1.75  | 1.92  | 1.99  | 2.24  | 2.74  |
| 16 | .47   | .56  | .66  | .76  | .85  | .95  | 1.04 | 1.14 | 1.23 | 1.33 | 1.42 | 1.61 | 1.80  | 1.90  | 1.99  | 2.18  | 2.26  | 2.55  | 3.12  |
| 18 | .54   | .65  | .76  | .86  | .97  | 1.08 | 1.19 | 1.30 | 1.41 | 1.52 | 1.63 | 1.85 | 2.06  | 2.17  | 2.28  | 2.50  | 2.59  | 2.92  | 3.57  |
| 20 | .66   | .80  | .93  | 1.07 | 1.20 | 1.34 | 1.47 | 1.61 | 1.74 | 1.87 | 2.01 | 2.28 | 2.55  | 2.68  | 2.82  | 3.09  | 3.21  | 3.61  | 4.42  |
| 22 | .72   | .87  | 1.01 | 1.16 | 1.31 | 1.45 | 1.60 | 1.74 | 1.89 | 2.04 | 2.18 | 2.48 | 2.77  | 2.91  | 3.06  | 3.35  | 3.51  | 3.95  | 4.83  |
| 24 | .79   | .95  | 1.11 | 1.27 | 1.43 | 1.59 | 1.75 | 1.91 | 2.07 | 2.23 | 2.39 | 2.71 | 3.03  | 3.19  | 3.35  | 3.67  | 3.83  | 4.31  | 5.27  |
| 26 | .87   | 1.05 | 1.23 | 1.40 | 1.58 | 1.76 | 1.93 | 2.11 | 2.29 | 2.47 | 2.64 | 3.0  | 3.35  | 3.53  | 3.7   | 4.06  | 4.24  | 4.78  | 5.83  |
| 28 | .95   | 1.14 | 1.34 | 1.53 | 1.72 | 1.91 | 2.10 | 2.30 | 2.49 | 2.69 | 2.88 | 3.26 | 3.65  | 3.84  | 4.03  | 4.42  | 4.62  | 5.19  | 6.35  |
| 30 | 1.04  | 1.25 | 1.46 | 1.66 | 1.89 | 2.10 | 2.31 | 2.52 | 2.73 | 2.94 | 3.15 | 3.57 | 4.0   | 4.21  | 4.42  | 4.84  | 5.06  | 5.70  | 6.96  |
| 32 | 1.15  | 1.39 | 1.62 | 1.86 | 2.09 | 2.32 | 2.56 | 2.79 | 3.03 | 3.26 | 3.49 | 3.96 | 4.43  | 4.66  | 4.90  | 5.36  | 5.63  | 6.33  | 7.73  |
| 36 | 1.29  | 1.56 | 1.82 | 2.08 | 2.34 | 2.60 | 2.87 | 3.13 | 3.39 | 3.65 | 3.91 | 4.44 | 4.96  | 5.22  | 5.49  | 6.01  | 6.30  | 7.08  | 8.66  |
| 40 | 1.42  | 1.71 | 2.0  | 2.28 | 2.57 | 2.88 | 3.14 | 3.43 | 3.72 | 4.01 | 4.30 | 4.87 | 5.45  | 5.73  | 6.02  | 6.60  | 6.90  | 7.76  | 9.49  |
| 42 | 1.48  | 1.78 | 2.08 | 2.37 | 2.67 | 2.97 | 3.27 | 3.57 | 3.87 | 4.17 | 4.47 | 5.07 | 5.67  | 5.96  | 6.26  | 6.86  | 7.19  | 8.09  | 9.91  |
| 44 | 1.55  | 1.86 | 2.17 | 2.48 | 2.80 | 3.11 | 3.42 | 3.74 | 4.05 | 4.36 | 4.68 | 5.30 | 5.93  | 6.24  | 6.55  | 7.18  | 7.50  | 8.44  | 10.32 |
| 48 | 1.67  | 2.01 | 2.35 | 2.69 | 3.03 | 3.36 | 3.70 | 4.04 | 4.38 | 4.72 | 5.06 | 5.73 | 6.41  | 6.75  | 7.09  | 7.76  | 8.10  | 9.12  | 11.15 |
| 54 | 1.92  | 2.31 | 2.70 | 3.09 | 3.48 | 3.87 | 4.26 | 4.65 | 5.04 | 5.43 | 5.82 | 6.60 | 7.38  | 7.77  | 8.16  | 8.94  | 9.31  | 10.50 | 12.84 |
| 60 | 2.18  | 2.62 | 3.06 | 3.50 | 3.94 | 4.39 | 4.82 | 5.26 | 5.70 | 6.14 | 6.58 | 7.46 | 8.34  | 8.78  | 9.22  | 10.11 | 10.57 | 11.86 | 14.54 |
| 72 | 2.67  | 3.21 | 3.75 | 4.29 | 4.83 | 5.37 | 5.91 | 6.46 | 7.0  | 7.54 | 8.08 | 9.16 | 10.24 | 10.78 | 11.32 | 12.40 | 13.0  | 14.62 | 17.86 |

# Series FEP

## Fiberglass End-Pivoted Automatic Shutter

Constructed entirely of fiberglass, the Series FEP Fiberglass End-Pivoted Automatic Shutter is recommended for gravity backdraft prevention applications used in conjunction with low pressure, low velocity fans, such as propeller fans and utility sets. It is best suited for applications where corrosive elements exist in fume or vapor form.

### Advantages of Fiberglass Construction:

- Superior corrosion resistance
- Excellent dimensional stability - It will not become brittle at low temperatures and at 0°F, laminated fiberglass will be stronger than at room temperature
- Strength-to-weight ratio 43% greater than that of aluminum

### Features:

- **FRP Construction** - All parts are constructed of fiberglass and isophthalic vinyl resin with a Class I flame spread rate of 25 or less and utilize woven fiberglass mat material for superior strength. All surfaces are protected for ultra-violet resistance. Joints are bonded with an industrial grade epoxy adhesive, having similar corrosion resistant properties as a vinylester resin.
- **Sizes** - Available in standard and custom sizes
- **Temperature** - Suitable for temperatures up to 200°F
- **Maximum Face Velocity** - 2,500 FPM
- **Maximum Differential Pressure** - 1" W.G.
- **Maximum Panel Size** - 48" W x 48" H. Larger size units are available in multiple panel construction with special reinforced manufacturing techniques.
- **Minimum Panel Size** - 12" W x 12" H
- **Frame** - 4" x 1<sup>1</sup>/<sub>16</sub>" x 1<sup>1</sup>/<sub>8</sub>" fiberglass reinforced isophthalic vinyl resin
- **Blades** - Minimum .070" thick fiberglass reinforced isophthalic vinyl resin
- **Stops** - 1<sup>1</sup>/<sub>8</sub>" fiberglass reinforced isophthalic vinyl resin angle
- **Axles** - 3<sup>3</sup>/<sub>4</sub>" diameter fiberglass reinforced isophthalic vinyl resin rod
- **Bearings** - Fiber reinforced thermoplastic
- **Color** - Medium gray is standard. Other colors available upon request.
- **Mounting Configurations** - Available in duct or flange mount.



### Ratings for Air Performance & Leakage

Hartzell Air Movement certifies that the Series FEP Fiberglass End-Pivoted Automatic Shutter air performance ratings shown herein are reliable and accurate and in accordance with industry standards. Ratings are based on tests and procedures performed in accordance with AMCA Standard 500.

## Performance Data

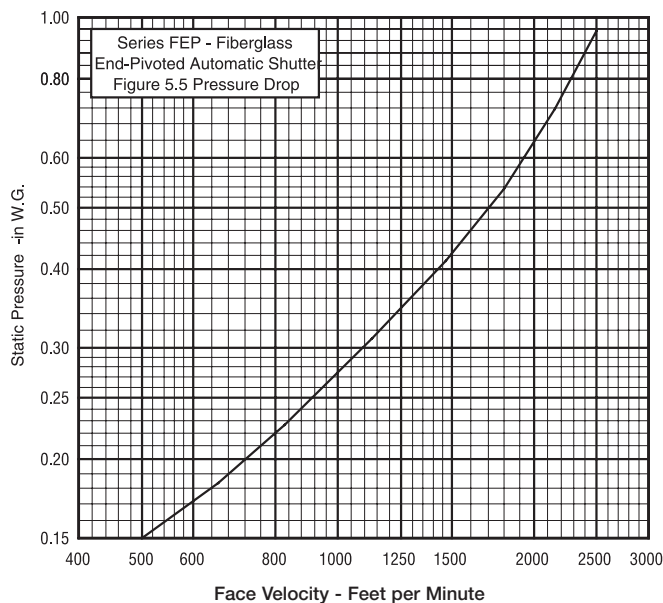

# Dimensions: Series FEP

## Duct Mount

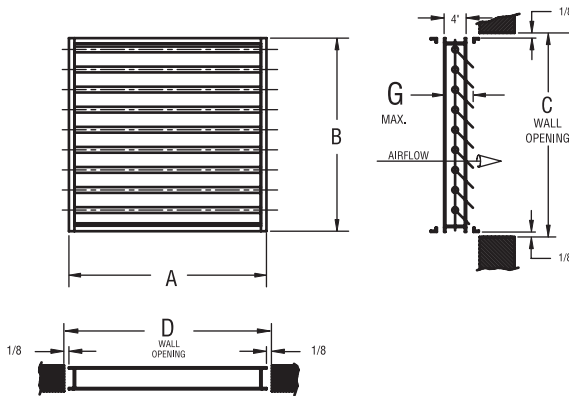

## Duct Mount Dimensions (in.) – Series FEP

| Nominal Shutter Size | A  | B  | C                 | D                 | G                  |
|----------------------|----|----|-------------------|-------------------|--------------------|
| 12                   | 12 | 12 | 12 <sup>1/4</sup> | 12 <sup>1/4</sup> | 6 <sup>1/4</sup>   |
| 14                   | 14 | 14 | 14 <sup>1/4</sup> | 14 <sup>1/4</sup> | 6 <sup>1/4</sup>   |
| 16                   | 16 | 16 | 16 <sup>1/4</sup> | 16 <sup>1/4</sup> | 6 <sup>1/4</sup>   |
| 18                   | 18 | 18 | 18 <sup>1/4</sup> | 18 <sup>1/4</sup> | 6 <sup>1/4</sup>   |
| 20                   | 20 | 20 | 20 <sup>1/4</sup> | 20 <sup>1/4</sup> | 6 <sup>1/4</sup>   |
| 22                   | 22 | 22 | 22 <sup>1/4</sup> | 22 <sup>1/4</sup> | 8 <sup>13/16</sup> |
| 24                   | 24 | 24 | 24 <sup>1/4</sup> | 24 <sup>1/4</sup> | 6 <sup>1/4</sup>   |
| 26                   | 26 | 26 | 26 <sup>1/4</sup> | 26 <sup>1/4</sup> | 8 <sup>13/16</sup> |
| 28                   | 28 | 28 | 28 <sup>1/4</sup> | 28 <sup>1/4</sup> | 8 <sup>13/16</sup> |
| 30                   | 30 | 30 | 30 <sup>1/4</sup> | 30 <sup>1/4</sup> | 8 <sup>13/16</sup> |
| 32                   | 32 | 32 | 32 <sup>1/4</sup> | 32 <sup>1/4</sup> | 8 <sup>13/16</sup> |
| 36                   | 36 | 36 | 36 <sup>1/4</sup> | 36 <sup>1/4</sup> | 8 <sup>13/16</sup> |
| 40                   | 40 | 40 | 40 <sup>1/4</sup> | 40 <sup>1/4</sup> | 8 <sup>13/16</sup> |
| 42                   | 42 | 42 | 42 <sup>1/4</sup> | 42 <sup>1/4</sup> | 8 <sup>13/16</sup> |
| 44                   | 44 | 44 | 44 <sup>1/4</sup> | 44 <sup>1/4</sup> | 8 <sup>13/16</sup> |
| 48                   | 48 | 48 | 48 <sup>1/4</sup> | 48 <sup>1/4</sup> | 8 <sup>13/16</sup> |
| 54                   | 54 | 54 | 54 <sup>1/4</sup> | 54 <sup>1/4</sup> | 8 <sup>13/16</sup> |
| 60                   | 60 | 60 | 60 <sup>1/4</sup> | 60 <sup>1/4</sup> | 8 <sup>13/16</sup> |

## Flange Mount

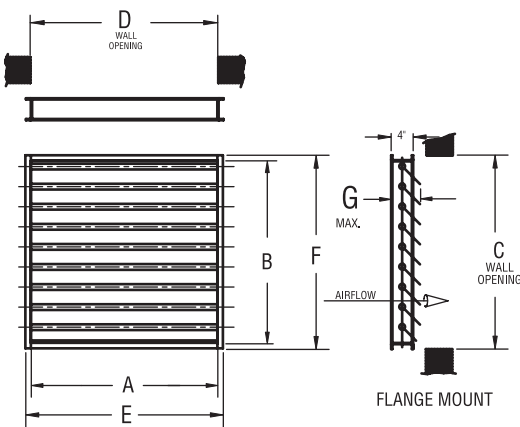

## Flange Mount Dimensions (in.) – Series FEP

| Nominal Shutter Size | A  | B  | C                 | D                 | E                 | F                 | G                  |
|----------------------|----|----|-------------------|-------------------|-------------------|-------------------|--------------------|
| 12                   | 12 | 12 | 12 <sup>1/4</sup> | 12 <sup>1/4</sup> | 14 <sup>1/8</sup> | 14 <sup>1/8</sup> | 6 <sup>1/4</sup>   |
| 14                   | 14 | 14 | 14 <sup>1/4</sup> | 14 <sup>1/4</sup> | 16 <sup>1/8</sup> | 16 <sup>1/8</sup> | 6 <sup>1/4</sup>   |
| 16                   | 16 | 16 | 16 <sup>1/4</sup> | 16 <sup>1/4</sup> | 18 <sup>1/8</sup> | 18 <sup>1/8</sup> | 6 <sup>1/4</sup>   |
| 18                   | 18 | 18 | 18 <sup>1/4</sup> | 18 <sup>1/4</sup> | 20 <sup>1/8</sup> | 20 <sup>1/8</sup> | 6 <sup>1/4</sup>   |
| 20                   | 20 | 20 | 20 <sup>1/4</sup> | 20 <sup>1/4</sup> | 22 <sup>1/8</sup> | 22 <sup>1/8</sup> | 8 <sup>13/16</sup> |
| 22                   | 22 | 22 | 22 <sup>1/4</sup> | 22 <sup>1/4</sup> | 24 <sup>1/8</sup> | 24 <sup>1/8</sup> | 6 <sup>1/4</sup>   |
| 24                   | 24 | 24 | 24 <sup>1/4</sup> | 24 <sup>1/4</sup> | 26 <sup>1/8</sup> | 26 <sup>1/8</sup> | 6 <sup>1/4</sup>   |
| 26                   | 26 | 26 | 26 <sup>1/4</sup> | 26 <sup>1/4</sup> | 28 <sup>1/8</sup> | 28 <sup>1/8</sup> | 6 <sup>1/4</sup>   |
| 28                   | 28 | 28 | 28 <sup>1/4</sup> | 28 <sup>1/4</sup> | 30 <sup>1/8</sup> | 30 <sup>1/8</sup> | 8 <sup>13/16</sup> |
| 30                   | 30 | 30 | 30 <sup>1/4</sup> | 30 <sup>1/4</sup> | 32 <sup>1/8</sup> | 32 <sup>1/8</sup> | 8 <sup>13/16</sup> |
| 32                   | 32 | 32 | 32 <sup>1/4</sup> | 32 <sup>1/4</sup> | 34 <sup>1/8</sup> | 34 <sup>1/8</sup> | 8 <sup>13/16</sup> |
| 36                   | 36 | 36 | 36 <sup>1/4</sup> | 36 <sup>1/4</sup> | 38 <sup>1/8</sup> | 38 <sup>1/8</sup> | 8 <sup>13/16</sup> |
| 40                   | 40 | 40 | 40 <sup>1/4</sup> | 40 <sup>1/4</sup> | 42 <sup>1/8</sup> | 42 <sup>1/8</sup> | 8 <sup>13/16</sup> |
| 42                   | 42 | 42 | 42 <sup>1/4</sup> | 42 <sup>1/4</sup> | 44 <sup>1/8</sup> | 44 <sup>1/8</sup> | 8 <sup>13/16</sup> |
| 44                   | 44 | 44 | 44 <sup>1/4</sup> | 44 <sup>1/4</sup> | 46 <sup>1/8</sup> | 46 <sup>1/8</sup> | 8 <sup>13/16</sup> |
| 48                   | 48 | 48 | 48 <sup>1/4</sup> | 48 <sup>1/4</sup> | 50 <sup>1/8</sup> | 50 <sup>1/8</sup> | 8 <sup>13/16</sup> |
| 54                   | 54 | 54 | 54 <sup>1/4</sup> | 54 <sup>1/4</sup> | 56 <sup>1/8</sup> | 56 <sup>1/8</sup> | 8 <sup>13/16</sup> |
| 60                   | 60 | 60 | 60 <sup>1/4</sup> | 60 <sup>1/4</sup> | 62 <sup>1/8</sup> | 62 <sup>1/8</sup> | 8 <sup>13/16</sup> |

|   |    | BLADE WIDTH |    |            |
|---|----|-------------|----|------------|
|   |    | 12          | 48 | 60         |
| B<br>L<br>A<br>D<br>E<br><br>H<br>E<br>I<br>G<br>H<br>T | 48 | ONE PANEL   |    | TWO PANELS |
|   | 60 |             |    |            |

## Multiple Panel Units

For units larger than the 48" W x 48" H max. panel size

Multiple panels are fastened together with FRP strips adhered to the channel frame. Axles are 3/4" diameter FRP. For units up to 36", axles are 4" long each end. For units above 36", axles are full blade length.

Note: Dimensions and specifications are subject to change. Certified prints are available.

# Series FLC

## Fiberglass Low Velocity Center-Pivoted Damper



Constructed entirely of fiberglass, the Series FLC Fiberglass Low Velocity Center-Pivoted Damper is recommended for backdraft control applications used in conjunction with low pressure, low velocity fans, such as propeller fans, power roof ventilators and utility sets. It can be manually or motor operated and is best suited for applications where corrosive elements exist in fume or vapor form.

### Advantages of Fiberglass Construction:

- Superior corrosion resistance
- Excellent dimensional stability - It will not become brittle at low temperatures and at 0°F, laminated fiberglass will be stronger than at room temperature
- Strength-to-weight ratio 43% greater than that of aluminum

### Features:

- **FRP Construction** - All parts are constructed of fiberglass and isophthalic vinyl resin with a Class I flame spread rate of 25 or less and utilize woven fiberglass mat material for superior strength. All surfaces are protected for ultra-violet resistance. Joints are bonded with an industrial grade epoxy adhesive, having similar corrosion resistant properties as a vinylester resin.
- **Sizes** - Available in standard and custom sizes
- **Temperature** - Suitable for temperatures up to 200°F
- **Maximum Face Velocity** - 2,500 FPM
- **Maximum Differential Pressure** - 1" W.G.
- **Maximum Panel Size** - 48" W x 48" H. Larger size units are available in multiple panel construction with special reinforced manufacturing techniques.
- **Minimum Panel Size** - 12" W x 12" H
- **Frame** - 4" x 1 1/16" x 1/8" fiberglass reinforced isophthalic vinyl resin
- **Blades** - Minimum .070" thick fiberglass reinforced isophthalic vinyl resin
- **Stops** - 1/8" fiberglass reinforced isophthalic vinyl resin angle
- **Axles** - 3/4" diameter fiberglass reinforced isophthalic vinyl resin rod
- **Bearings** - Fiber reinforced thermoplastic
- **Color** - Medium gray is standard. Other colors available upon request.
- **Mounting Configurations** - Available in duct & flange mount configurations.

### Ratings for Air Performance & Leakage

Hartzell Air Movement certifies that the Series FLC Fiberglass Low Velocity, Center-Pivoted Damper air performance and leakage ratings shown herein are reliable and accurate and in accordance with industry standards. Ratings are based on tests and procedures performed in accordance with AMCA Standard 500.

### Performance Data

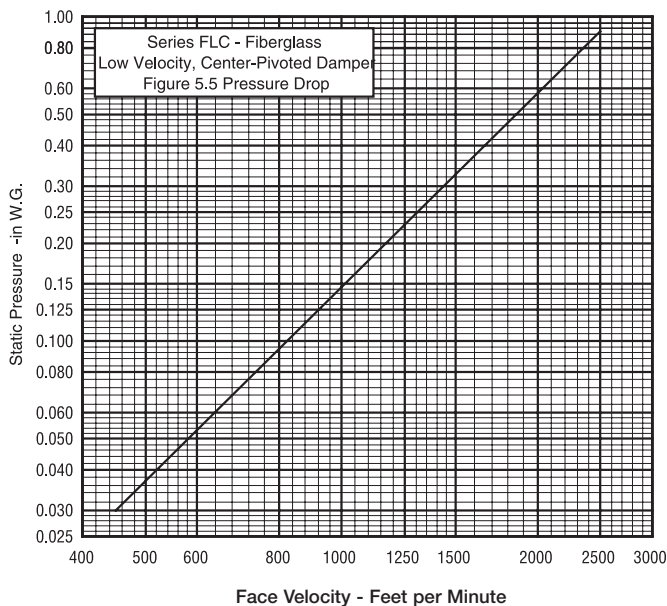

### Leakage

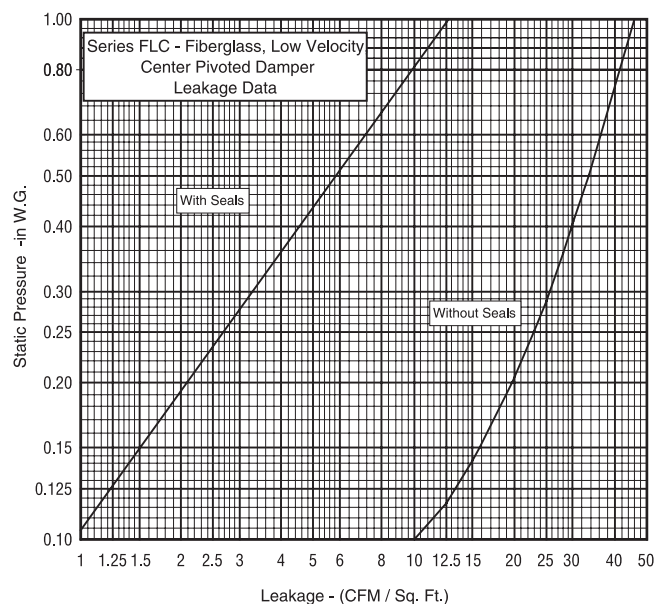

# Dimensions: Series FLC

## Duct Mount

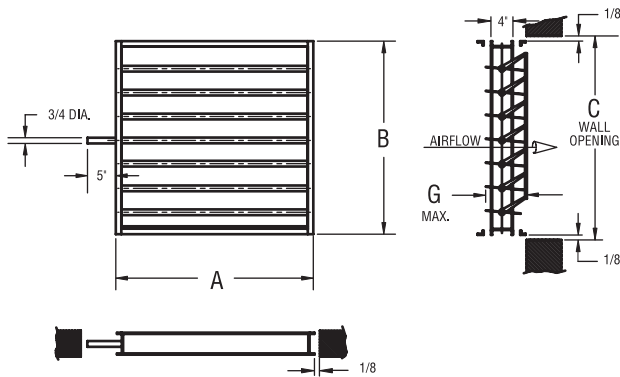

Warning: Allowances must be considered to eliminate side axle interference.

## Duct Mount Dimensions (in.) – Series FLC

| Nominal Damper Size | A  | B  | C                 | G                |
|---------------------|----|----|-------------------|------------------|
| 12                  | 12 | 12 | 12 <sup>1/4</sup> | 6 <sup>1/4</sup> |
| 14                  | 14 | 14 | 14 <sup>1/4</sup> | 6 <sup>1/4</sup> |
| 16                  | 16 | 16 | 16 <sup>1/4</sup> | 6 <sup>1/4</sup> |
| 18                  | 18 | 18 | 18 <sup>1/4</sup> | 6 <sup>1/4</sup> |
| 20                  | 20 | 20 | 20 <sup>1/4</sup> | 6 <sup>1/4</sup> |
| 22                  | 22 | 22 | 22 <sup>1/4</sup> | 6 <sup>1/4</sup> |
| 24                  | 24 | 24 | 24 <sup>1/4</sup> | 6 <sup>1/4</sup> |
| 26                  | 26 | 26 | 26 <sup>1/4</sup> | 6 <sup>1/4</sup> |
| 28                  | 28 | 28 | 28 <sup>1/4</sup> | 6 <sup>1/4</sup> |
| 30                  | 30 | 30 | 30 <sup>1/4</sup> | 6 <sup>1/4</sup> |
| 32                  | 32 | 32 | 32 <sup>1/4</sup> | 6 <sup>1/4</sup> |
| 36                  | 36 | 36 | 36 <sup>1/4</sup> | 9 <sup>5/8</sup> |
| 40                  | 40 | 40 | 40 <sup>1/4</sup> | 9 <sup>5/8</sup> |
| 42                  | 42 | 42 | 42 <sup>1/4</sup> | 9 <sup>5/8</sup> |
| 44                  | 44 | 44 | 44 <sup>1/4</sup> | 9 <sup>5/8</sup> |
| 48                  | 48 | 48 | 48 <sup>1/4</sup> | 9 <sup>5/8</sup> |
| 54                  | 54 | 54 | 54 <sup>1/4</sup> | 9 <sup>5/8</sup> |
| 60                  | 60 | 60 | 60 <sup>1/4</sup> | 9 <sup>5/8</sup> |

## Flange Mount

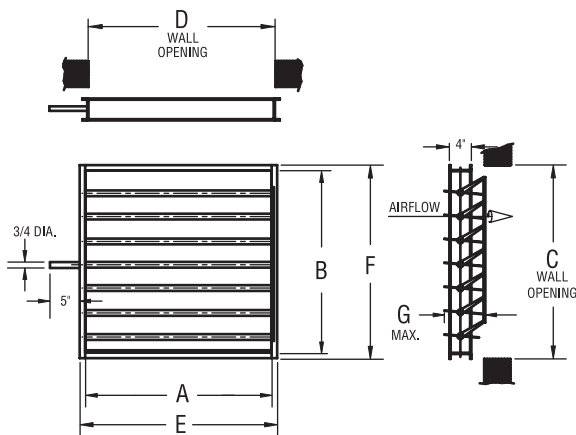

## Flange Mount Dimensions (in.) – Series FLC

| Nominal Damper Size | A  | B  | C                 | D                 | E                 | F                 | G                |
|---------------------|----|----|-------------------|-------------------|-------------------|-------------------|------------------|
| 12                  | 12 | 12 | 12 <sup>1/4</sup> | 12 <sup>1/4</sup> | 14 <sup>1/8</sup> | 14 <sup>1/8</sup> | 6 <sup>1/4</sup> |
| 14                  | 14 | 14 | 14 <sup>1/4</sup> | 14 <sup>1/4</sup> | 16 <sup>1/8</sup> | 16 <sup>1/8</sup> | 6 <sup>1/4</sup> |
| 16                  | 16 | 16 | 16 <sup>1/4</sup> | 16 <sup>1/4</sup> | 18 <sup>1/8</sup> | 18 <sup>1/8</sup> | 6 <sup>1/4</sup> |
| 18                  | 18 | 18 | 18 <sup>1/4</sup> | 18 <sup>1/4</sup> | 20 <sup>1/8</sup> | 20 <sup>1/8</sup> | 6 <sup>1/4</sup> |
| 20                  | 20 | 20 | 20 <sup>1/4</sup> | 20 <sup>1/4</sup> | 22 <sup>1/8</sup> | 22 <sup>1/8</sup> | 6 <sup>1/4</sup> |
| 22                  | 22 | 22 | 22 <sup>1/4</sup> | 22 <sup>1/4</sup> | 24 <sup>1/8</sup> | 24 <sup>1/8</sup> | 6 <sup>1/4</sup> |
| 24                  | 24 | 24 | 24 <sup>1/4</sup> | 24 <sup>1/4</sup> | 26 <sup>1/8</sup> | 26 <sup>1/8</sup> | 6 <sup>1/4</sup> |
| 26                  | 26 | 26 | 26 <sup>1/4</sup> | 26 <sup>1/4</sup> | 28 <sup>1/8</sup> | 28 <sup>1/8</sup> | 6 <sup>1/4</sup> |
| 28                  | 28 | 28 | 28 <sup>1/4</sup> | 28 <sup>1/4</sup> | 30 <sup>1/8</sup> | 30 <sup>1/8</sup> | 6 <sup>1/4</sup> |
| 30                  | 30 | 30 | 30 <sup>1/4</sup> | 30 <sup>1/4</sup> | 32 <sup>1/8</sup> | 32 <sup>1/8</sup> | 6 <sup>1/4</sup> |
| 32                  | 32 | 32 | 32 <sup>1/4</sup> | 32 <sup>1/4</sup> | 34 <sup>1/8</sup> | 34 <sup>1/8</sup> | 6 <sup>1/4</sup> |
| 36                  | 36 | 36 | 36 <sup>1/4</sup> | 36 <sup>1/4</sup> | 38 <sup>1/8</sup> | 38 <sup>1/8</sup> | 9 <sup>5/8</sup> |
| 40                  | 40 | 40 | 40 <sup>1/4</sup> | 40 <sup>1/4</sup> | 42 <sup>1/8</sup> | 42 <sup>1/8</sup> | 9 <sup>5/8</sup> |
| 42                  | 42 | 42 | 42 <sup>1/4</sup> | 42 <sup>1/4</sup> | 44 <sup>1/8</sup> | 44 <sup>1/8</sup> | 9 <sup>5/8</sup> |
| 44                  | 44 | 44 | 44 <sup>1/4</sup> | 44 <sup>1/4</sup> | 46 <sup>1/8</sup> | 46 <sup>1/8</sup> | 9 <sup>5/8</sup> |
| 48                  | 48 | 48 | 48 <sup>1/4</sup> | 48 <sup>1/4</sup> | 50 <sup>1/8</sup> | 50 <sup>1/8</sup> | 9 <sup>5/8</sup> |
| 54                  | 54 | 54 | 54 <sup>1/4</sup> | 54 <sup>1/4</sup> | 56 <sup>1/8</sup> | 56 <sup>1/8</sup> | 9 <sup>5/8</sup> |
| 60                  | 60 | 60 | 60 <sup>1/4</sup> | 60 <sup>1/4</sup> | 62 <sup>1/8</sup> | 62 <sup>1/8</sup> | 9 <sup>5/8</sup> |

|              |    | BLADE WIDTH |            |
|--------------|----|-------------|------------|
| BLADE HEIGHT | 12 | 48          | 60         |
|              | 48 | ONE PANEL   | TWO PANELS |
|              | 60 |             |            |

## Multiple Panel Units

For units larger than the 48" W x 48" H max. panel size

Multiple panels are fastened together with FRP strips adhered to the channel frame. Axles are 3/4" diameter FRP. For units up to 36", axles are 4" long each end. For units above 36", axles are full blade length.

Note: Dimensions and specifications are subject to change. Certified prints are available.

# Series FCO & FCP

## Fiberglass Center-Pivoted Volume Control Dampers

Constructed entirely of fiberglass, the Series FCO & FCP Fiberglass Center-Pivoted Volume Control Dampers are recommended for system balance, back flow prevention and/or fan isolation applications used in conjunction with medium to high pressure process ventilation or fume exhaust systems. Series FCO is opposed blade and Series FCP is parallel blade. Both units can be manually or motor operated and are best suited for applications where corrosive elements exist in fume or vapor form.

### Advantages of Fiberglass Construction:

- Superior corrosion resistance
- Excellent dimensional stability - It will not become brittle at low temperatures and at 0°F, laminated fiberglass will be stronger than at room temperature
- Strength-to-weight ratio 43% greater than that of aluminum

### Features:

- **FRP Construction** - All parts are constructed of fiberglass and isophthalic vinyl resin with a Class I flame spread rate of 25 or less and utilize woven fiberglass mat material for superior strength. All surfaces are protected for ultra-violet resistance. Joints are bonded with an industrial grade epoxy adhesive, having similar corrosion resistant properties as a vinylester resin.
- **Sizes** - Available in standard and custom sizes
- **Temperature** - Suitable for temperatures up to 200°F
- **Maximum Face Velocity** - 6,000 FPM
- **Maximum Differential Pressure** - 20" W.G.
- **Maximum Panel Size** - Maximum single panel size is determined by the system static pressure. At high pressures, multi-panel may be required. Refer to the "Damper Maximum Blade Length vs. Static Pressure" illustration.
- **Frame** - 8" x 2<sup>11</sup>/<sub>16</sub>" x 3<sup>3</sup>/<sub>16</sub>" fiberglass reinforced isophthalic vinyl resin
- **Blades** - Minimum 3<sup>3</sup>/<sub>16</sub>" thick fiberglass reinforced isophthalic vinyl resin
- **Linkage** - Stainless steel enclosed in damper frame, outside of airstream
- **Operation** - Control shaft may be located on either side, with options.
- **Stops** - 1<sup>1</sup>/<sub>8</sub>" fiberglass reinforced isophthalic vinyl resin angle
- **Axles** - 3<sup>3</sup>/<sub>4</sub>" diameter fiberglass reinforced isophthalic vinyl resin rod
- **Bearings** - Fiber reinforced thermoplastic
- **Color** - Medium gray is standard. Other colors available upon request.



**Series FCO**  
Opposed Blade



**Series FCP**  
Parallel Blade

### Ratings for Air Performance & Leakage

Hartzell Air Movement certifies that the Series FCO & FCP Fiberglass Volume Control Dampers air performance and leakage ratings shown herein are reliable and accurate and in accordance with industry standards. Ratings are based on tests and procedures performed in accordance with AMCA Standard 500.

### Performance Data

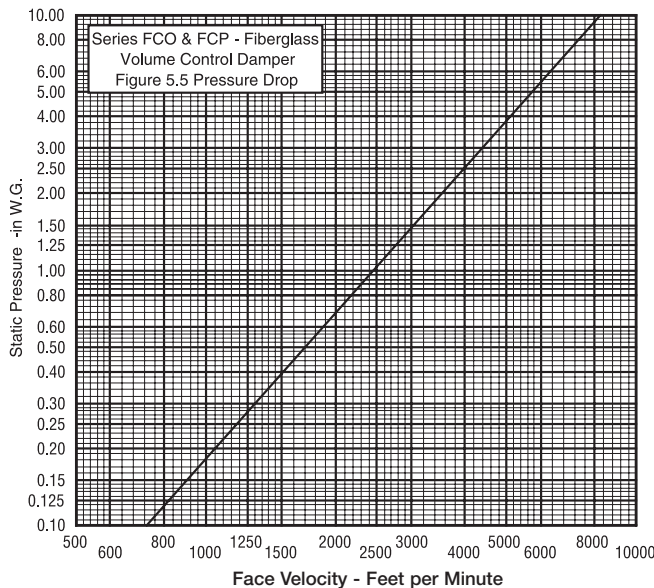

### Leakage

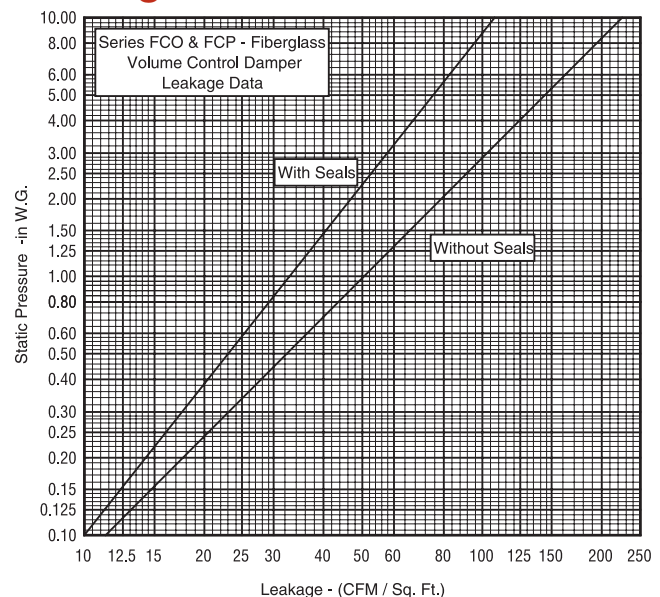

# Dimensions: Series FCO & FCP

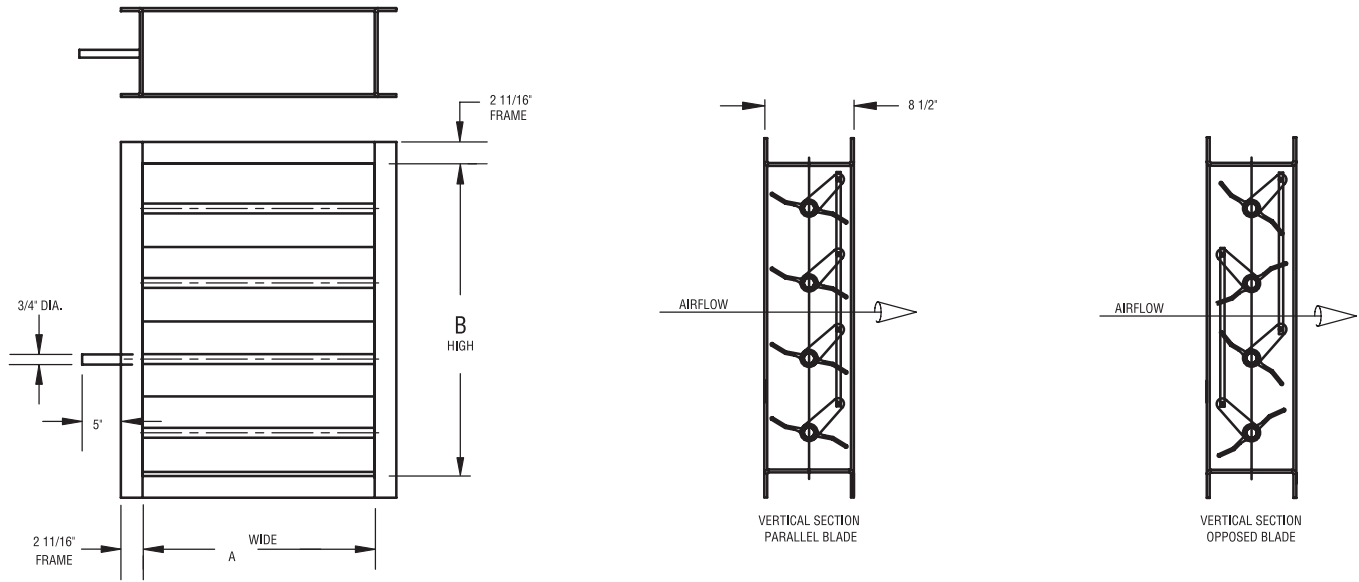

Dimensions A and B to match customer requirements

## Damper Maximum Blade Length vs. Static Pressure

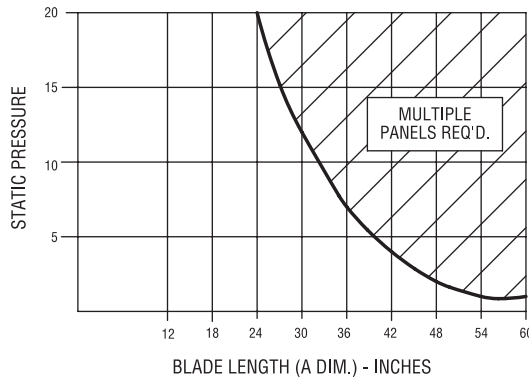

### Maximum panel size is determined by the system static pressure

The chart indicates maximum blade length as a function of system static pressure. When, at a given pressure condition, longer blades are required, jack-shafted, multi-panel construction shall be used. In those cases additional detail will be supplied on special factory drawings.

## Damper Operational Torque

**in.-lbs.**

|    | 12  | 18   | 24   | 30   | 36   | 42   | 48   | 54   | 60   |
|----|-----|------|------|------|------|------|------|------|------|
| 12 | 1.6 | 2.4  | 3.2  | 4.0  | 4.8  | 5.6  | 6.4  | 7.2  | 8.0  |
| 18 | 2.4 | 3.6  | 4.8  | 6.0  | 7.2  | 8.4  | 9.6  | 10.8 | 12.0 |
| 24 | 3.2 | 4.8  | 6.4  | 8.0  | 9.6  | 11.2 | 12.8 | 14.4 | 15.9 |
| 30 | 4.0 | 6.0  | 8.0  | 10.0 | 12.0 | 14.0 | 15.9 | 17.9 | 19.9 |
| 36 | 4.8 | 7.2  | 9.6  | 12.0 | 14.4 | 16.8 | 19.1 | 21.5 | 23.9 |
| 42 | 5.6 | 8.4  | 11.2 | 14.0 | 16.8 | 19.5 | 22.3 | 25.1 | 27.9 |
| 48 | 6.4 | 9.6  | 12.8 | 15.9 | 19.1 | 22.3 | 25.5 | 28.7 | 31.9 |
| 54 | 7.2 | 10.8 | 14.4 | 17.9 | 21.5 | 25.1 | 28.7 | 32.3 | 35.9 |
| 60 | 8.0 | 12.0 | 15.9 | 19.9 | 23.9 | 27.9 | 31.9 | 35.9 | 39.9 |

### Notes:

1. Table equals pressure torque in inch-pounds, at 1" differential static pressure.
2. For torque at different pressures, multiply differential pressure by tabulated values.
3. For torque values with jamb seals, multiply tabulated values by 1.36.

Dimensions and specifications are subject to change.  
Certified prints are available.

# Hartzell

**AIR MOVEMENT**

OTHER PRODUCTS INCLUDE:



CENTRIFUGAL  
EXHAUSTERS



ROOF VENTILATORS



DUCT FANS



DUCT AXIAL FANS



BACKWARD CURVED  
CENTRIFUGAL FANS



IN-LINE CENTRIFUGAL  
FANS



STEEL CENTRIFUGAL  
BLOWERS



PROP FANS &  
ROOF VENTILATORS

Craig Equipment Company

13055 MIDDLETOWN INDUSTRIAL BLVD, LOUISVILLE, KY 40223  
TF:800-928-7100 • T:502-245-4840 • F:502-245-1665 [craig-equip.com](http://craig-equip.com)

