



BS SERIES

Ideal for wood applications

Craig Equipment Company

13055 MIDDLETOWN INDUSTRIAL BLVD, LOUISVILLE, KY 40223
TF:800-928-7100 • T:502-245-4840 • F:502-245-1665 craig-equip.com



Sizes: 20"x20", 20"x30", 20"x40" & 20"x60"

STANDARD FEATURES

- Differential pressures up to 28" WC
- Direct drive gearmotor with flex coupling
- Explosion and flame proof to 7.25 PSI / 201" WC

OPTIONAL FEATURES

- Default: Steel with Neoprene Tip Rotor Blades
- Optional: Steel Rotor with Silicone Tip Blades or Stainless Steel Rotor with Polyurethane Tip Blades

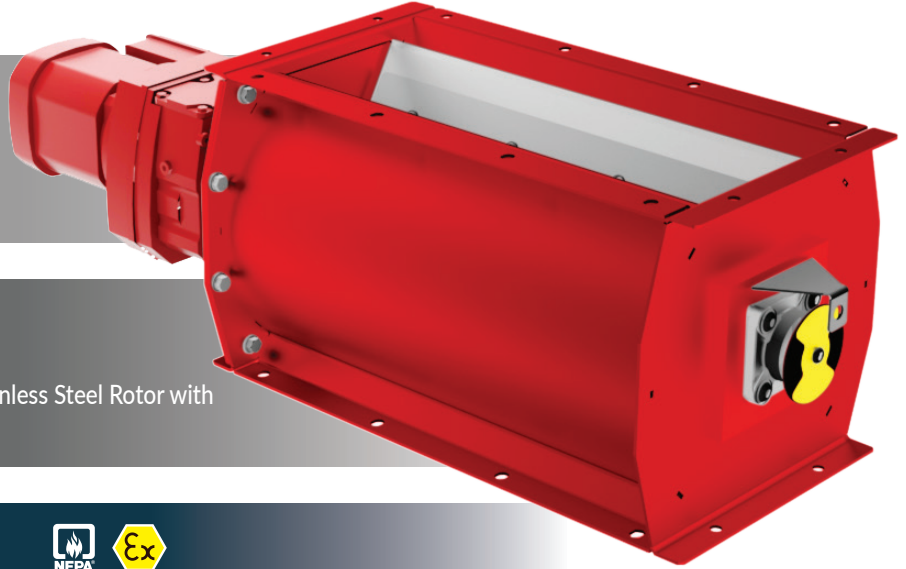

CERTIFICATIONS & STANDARDS



- NFPA 69 Compliant - ATEX Certified EN 15089
- OSHA Compliant drive guard for the Explosion Isolation Model
- External bearing design, 8-vane rotary blade for the Explosion Isolation
- Flex tip design certified to prevent flame passage for Passive Explosion Isolation

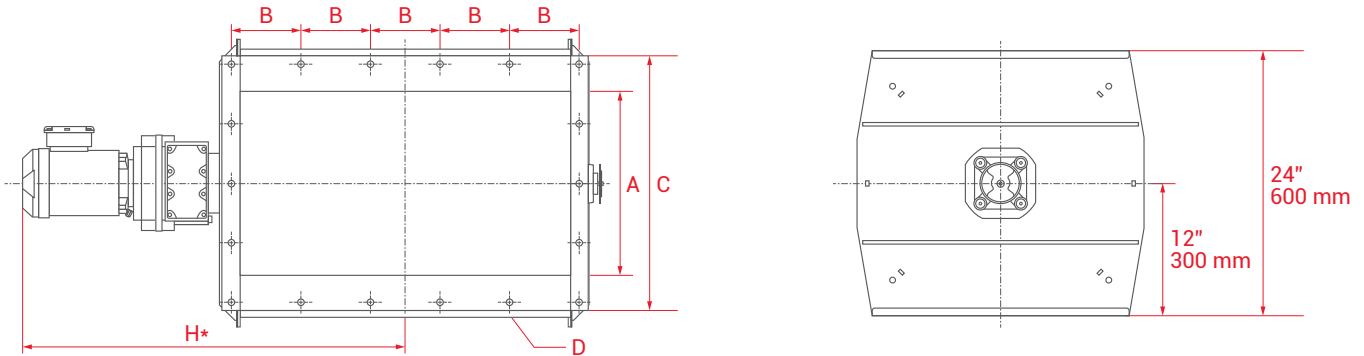

DIMENSIONS *

MODEL	15 RPM HP	22 RPM HP	CAPACITY FT ³ (LTR)	A	B	C	D	H
BS500	1.00		4.41 (125)/rev	20" x 20" (500 x 500mm)	0.16" x 5.30" (4 x 135mm)	23" x 23" (580 x 580mm)	16 x Ø10.5mm	30" (742mm)
BS750	1.00		6.64 (188)/rev	20" x 30" (500 x 750mm)	0.20" x 6.22" (5 x 158mm)	23" x 33" (580 x 830mm)	18 x Ø10.5mm	34" (867mm)
BS1000	1.50		8.83 (250)/rev	20" x 40" (500 x 1000mm)	0.31" x 5.12" (8 x 130mm)	23" x 43" (580 x 1080mm)	24 x Ø10.5mm	40" (997mm)

Available as BS, Rotary valve with explosion detector and control – Available as BS, Rotary valve only
* Length varies dependent on motor selection – Units in inches rounded to the closest whole number